

# OPERATING MANUAL

CR-2010<sup>Pro</sup>

CR-2010 PRO Series  
11" Recorder  
Model No.: 33xxx / 34xxx

Manufacturers of :

- Circular Chart Recorders
- Strip Chart Recorders
- Hygro-Thermographs
- Inkless Recorders
- Scanners & Data Loggers

**g-tek**<sup>TM</sup>  
Record it...  
Control it...  
Perfect it

**G-Tek Corporation Pvt. Ltd.**  
3, mahavir estate, karelibaug  
vadodara-390 018  
tel.: +91-265-2461912  
email: [info@gtek-india.com](mailto:info@gtek-india.com)  
url: [www.gtek-india.com](http://www.gtek-india.com)

# CONTENTS

Contents.....	1
1 List of Figures .....	3
2 List of Tables .....	4
3 Introduction .....	5
3.1 Manual Layout .....	5
3.2 Chart Recorder Description.....	5
3.3 Optional Features .....	6
3.4 Unpacking and Inspection of Recorder.....	6
4 Installation .....	8
4.1 Electrical Installation.....	11
4.1.1 General information.....	11
4.1.2 Wiring diagram for recorder .....	13
4.2 Fitting the Pen.....	22
4.3 Fitting the Chart .....	23
4.4 Replace Fuse (Battery backup).....	23
5 Operation .....	24
6 Configuration .....	25
6.1 Configurable Item .....	25
6.2 Functions.....	27
6.2.1 Chart Speed.....	27
6.2.2 Display Setting.....	28
6.2.3 Channel Scan .....	29
6.2.4 CJC.....	29
6.2.5 Pen Park .....	30
6.2.6 Change Pen .....	31
6.2.7 Channel 1 .....	32
6.2.8 Channel 2 .....	40
6.2.9 Channel 3 .....	40
6.2.10 Channel 4 .....	40
7 Calibration.....	41
7.1 Mechanical Calibration .....	41
8 Troubleshooting Guide .....	42
9 Accessories.....	43

10 Specification ..... 44

11 Ordering Code ..... 48

# 1 LIST OF FIGURES

Figure 1 - Unpacking and Inspection of Recorder.....	7
Figure 2 - Environmental Conditions and Overall Dimensions .....	8
Figure 3 - Pipe Mounting.....	9
Figure 4 - Wall Mounting .....	9
Figure 5 - Panel Mounting.....	10
Figure 6 – View of recorder after opening chart plate .....	14
Figure 7 – Power Supply PCB .....	16
Figure 8 – Sensor wiring.....	18
Figure 9 – Pin Descriptions of sensor connector .....	19
Figure 10 - Connecting Transmitter with recorder & other instrument using External Power Supply	20
Figure 11 - Connection of Recorder with Transmitter and Internal Power Supply .....	21
Figure 12 - Fitting / Replacing the Pen.....	22
Figure 13 - Chart Fitting .....	23
Figure 14 - Four Pen Recorder Front Panel.....	24
Figure 15 - Main menu display.....	26
Figure 16 - Chart speed.....	27
Figure 17 - Hour/Minute option .....	27
Figure 18- Display Setting .....	28
Figure 19 - Freeze Panel.....	28
Figure 20 - Action (Display).....	28
Figure 21 - Channel Skip.....	29
Figure 22 - CJC.....	30
Figure 23 - Pen Park .....	31
Figure 24 - Change Pen .....	32
Figure 25 - Channel Configuration .....	33
Figure 26 - RTD Sensor .....	34
Figure 27 - Sensor Selection.....	36
Figure 28 - Range Low Selection .....	37
Figure 29 - Span Selection.....	37
Figure 30 - Offset Selection.....	38
Figure 31 - Multiplier Selection.....	38
Figure 32 - Resolution Decimal Place.....	38
Figure 33 - Alarm Set point High .....	39
Figure 34 - Alarm Set Point Low.....	39
Figure 35 - Chart Zero .....	40
Figure 36 - Chart Span.....	40
Figure 37 - Mechanical calibration.....	41
Figure 38 - Accessories.....	43

## 2 LIST OF TABLES

---

Table 1 Manual Layout.....	5
Table 2 Sensor Wiring .....	20
Table 3 Configurable Items .....	25
Table 4 Troubleshooting Guide.....	42
Table 5 Specification of Chart Recorder .....	44
Table 6 Order code of Chart Recorder .....	48
Table 7 Chart type of Chart Recorder .....	49

### 3 INTRODUCTION

This manual is written to help the user to familiarize with the installation and operation of the smart chart series of circular chart recorders. These recorders can plot up to 3 or 4 individual channels using distinct color link cartridges. This Recorder is capable of monitoring 3 or 4 channels outputs at the scan rate of 1 second for each channel and plot the reading on chart with a pen per channel.

#### 3.1 MANUAL LAYOUT

This manual is divided into several sections for quick and easy reference.

Table 1 Manual Layout

Section 1 Introduction	This gives outline of the manual, brief description about the chart recorder, Optional features available and how to unpack it.
Section 2 Installation	This section gives the details of the led display and Electrical installation.
Section 3 Operation	This section gives the details of the front panel display and keyboard.
Section 4 Recorder Configuration	This section gives the details of various parameter that user can set using keyboard for proper monitoring requirement.
Section 5 Parameter Setting	This section describes the method of setting various parameters/programming sequence.
Section 6 Calibration	This section describes the mechanical calibration procedure for the recorder.
Section 7 Troubleshooting Guide	This section describes about the most frequently asked questions and their solutions.
Section 8 Accessories	This section describes the standard accessories for the recorder along with their part nos.
Section 9 Specification	It describes the detailed specification of the chart recorder.
Section 10 Ordering Code	It describes the details of order code and comparing it with the code on the chart recorder, user can find out the installed options.

#### 3.2 CHART RECORDER DESCRIPTION

The smart chart series of recorders come as 3 or 4 pens continuous marking circular chart recorder. This recorder is fitted with digital display. For the convenience of the user and to make it cost effective, universal inputs are made as an optional feature. User should specially order the universal input to have a fully configurable recorder. The chart recorder comes with on board Temperature, 3 or 4 input channels, led display and 3 or 4 pens. This led display allows user to continuously monitor the current reading with good readability and setting of configurations. This chart recorder also has 5 multipurpose keys which enables user to easy programming/configure the unit.

### 3.3 OPTIONAL FEATURES

Following features are available for this circular chart recorder.

- 11" Chart Width
- Digital, 8-digit ultra-bright LED Numeric / semi alphabetic Display
- Single & Dual Analog Input channel
- Direct Input standard PT-100 sensor
- Standard Input for popular Thermocouples like J/K/C/R/S/T/B/E/N
- Process Input through 4-20mA / 0-20mA / 0-5V
- Cost effective fixed sensor input or Field configurable sensor input
- 15 min/rev to 255 hour/rev chart speed
- Universal Power Supply 85-264 V AC, 47-63 Hz
- Other power supply inputs on request
- Battery Backup
- One relay per channel (Optional).

It is possible that the chart recorder you received may or may not be fitted with the optional features. Please refer to the product code to know about installed options in your chart recorder.

### 3.4 UNPACKING AND INSPECTION OF RECORDER

G-Tek recorders are dispatched in a recyclable, environment friendly package specially designed to give adequate protection during transit. If the outer box shows sign of damage, it should be opened immediately, and the recorder be examined. If there is evidence of damage, the instrument should not be operated, and the local representative contacted for instructions. Ensure that all accessories and documentation is removed from the box. Open the door of the recorder by rotating the knob (figure A). Open the chart plate by opening the captive Screw (figure B) and inspect the recorder for an immediate use, re-pack the recorder in its original packing. If the recorder is for immediate use, you can start installing it now as per following instructions. **Please preserve the original packing along with all internal packing for future transport requirements.**

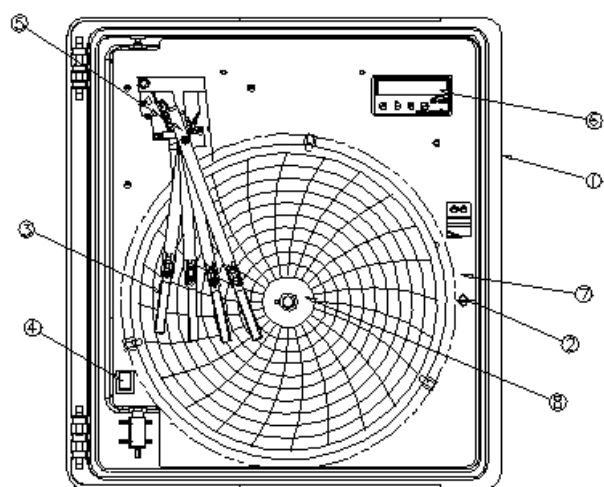

1. BASE BOX
2. CAPTIVE SCREW
3. PEN ARM
4. MAINS ON/OFF SWITCH
5. C CLAMP
6. KEYBOARD AND DISPLAY
7. CHART PLATE
8. CHART ADAPTER

Figure A

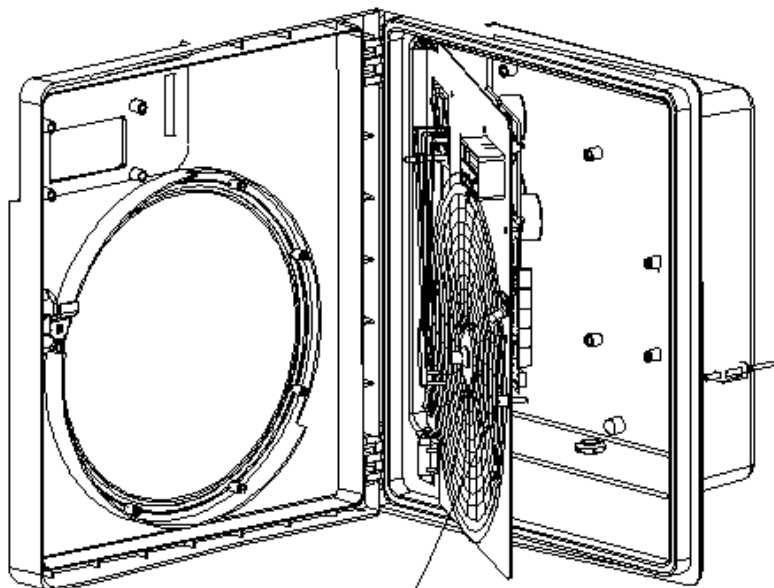

After opening the door, loosen the captive screws to open the chart plate

Figure B

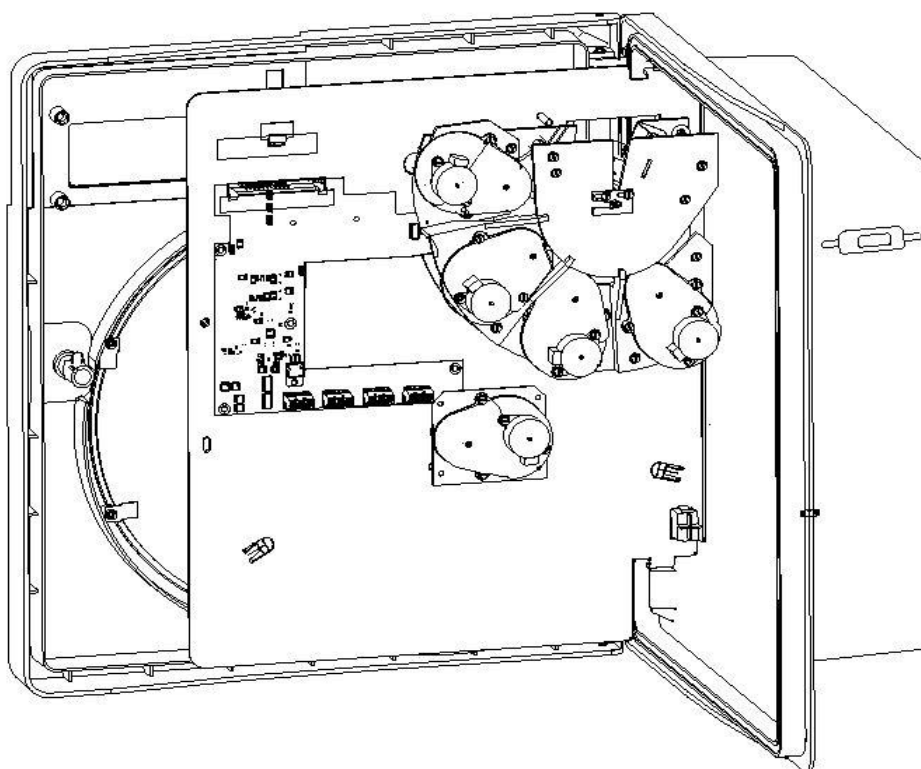

After Opening the chart plate the recorder will look as seen in Fig(C).

Figure C

Figure 1 - Unpacking and Inspection of Recorder



## 4 INSTALLATION

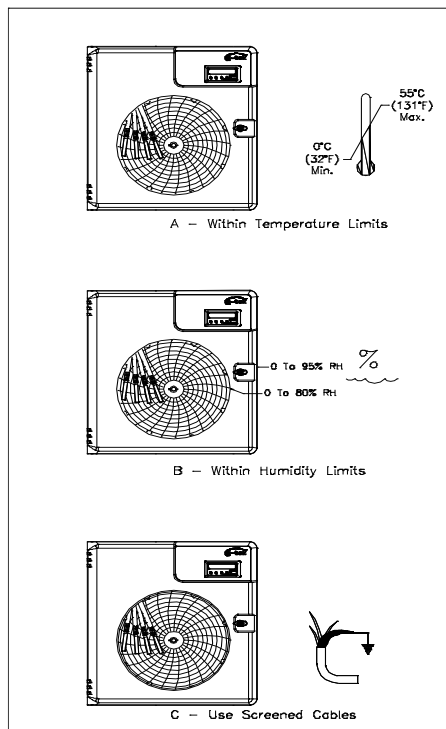
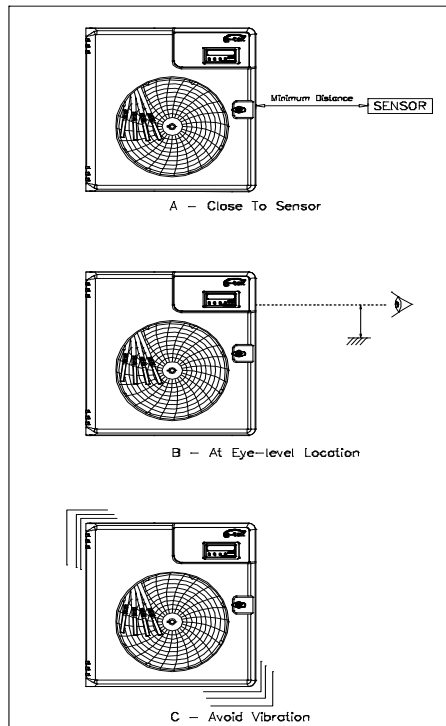

**Caution:**

Select a location away from strong electrical and magnetic field. If it is not possible, particular in the application where mobile communication equipment is expected to be used, screened cables within earthed (grounded) metal contact must be used.

**ENVIRONMENTAL CONDITIONS**

Figure 2.1

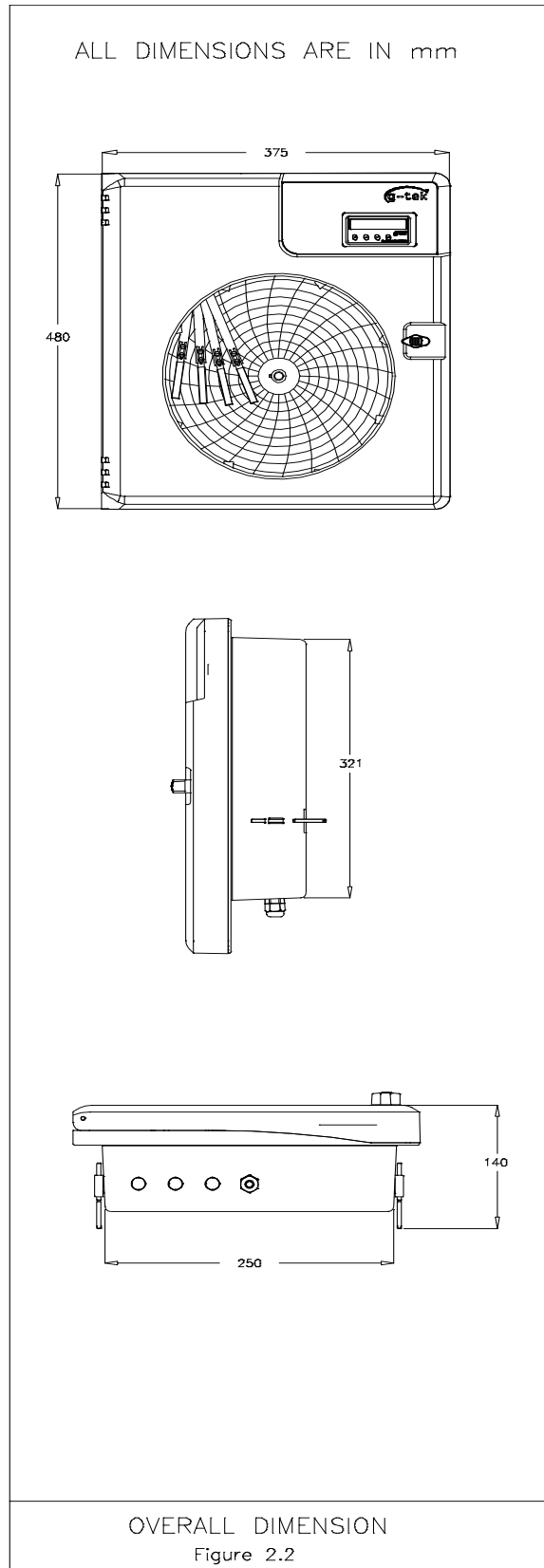

Figure 2 - Environmental Conditions and Overall Dimensions

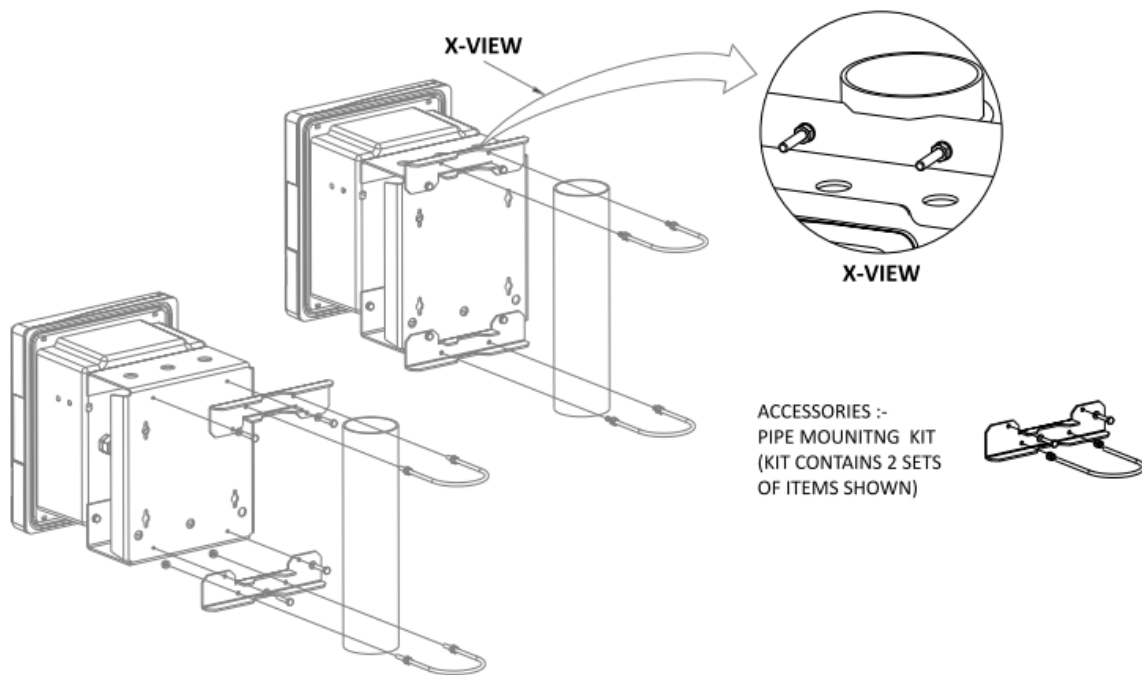

Figure 3 - Pipe Mounting

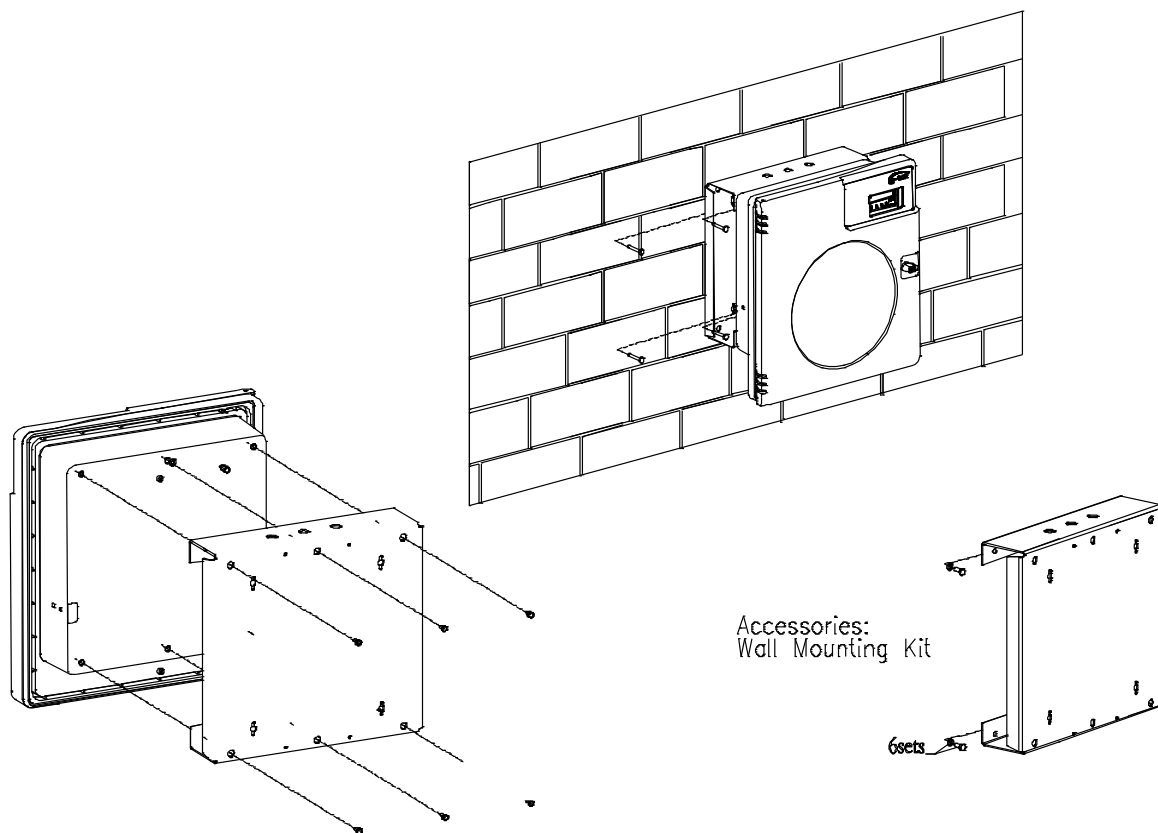

Figure 4 - Wall Mounting

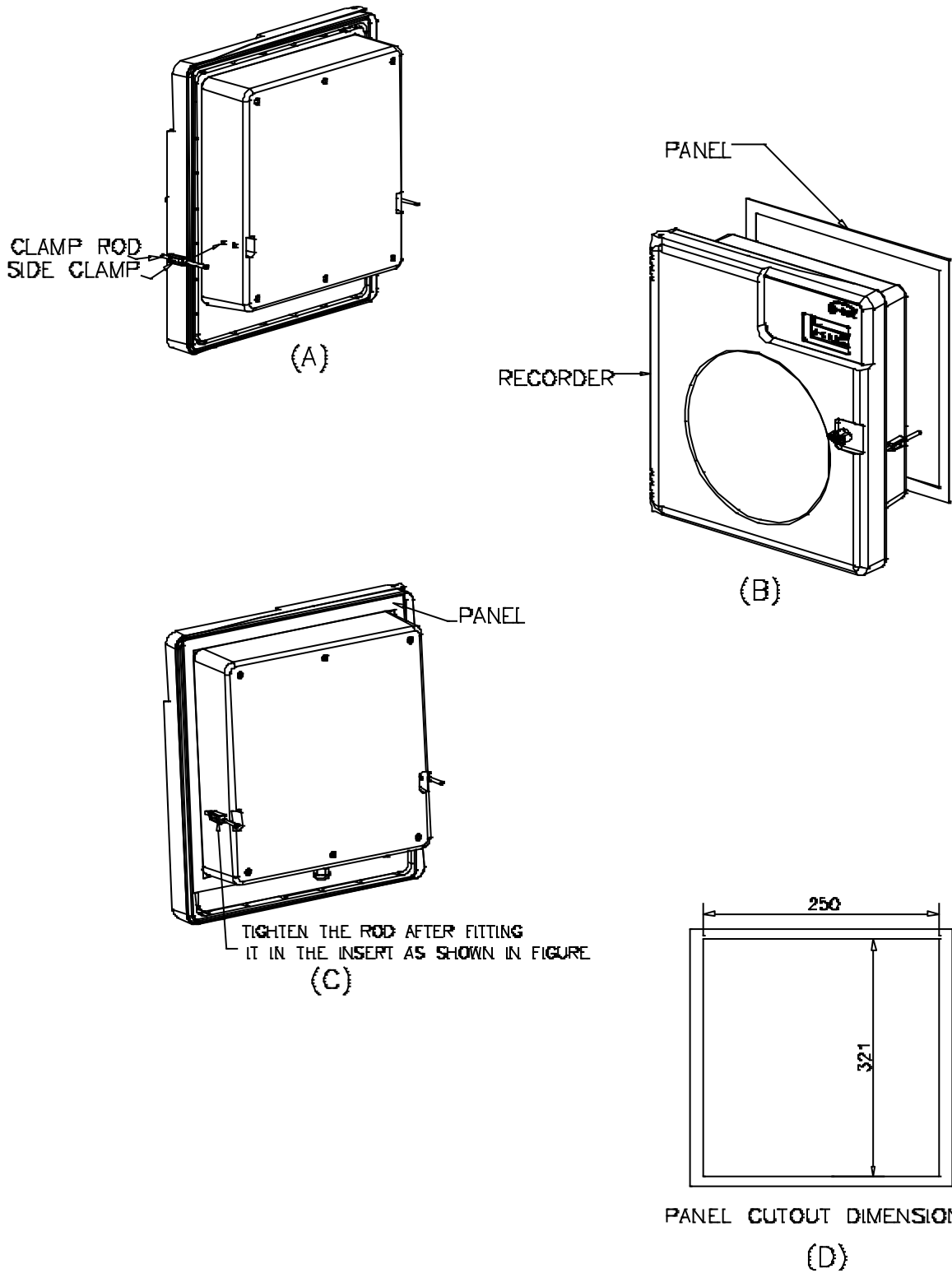

Figure 5 - Panel Mounting

## 4.1 ELECTRICAL INSTALLATION

### 4.1.1 General information



#### Warnings

To comply with Underwriter Laboratories (UL) and Canadian Standards Association (CSA) certification, route signal leads and power cables in earthed (grounded), flexible metal conduit. Use the protective ground stud at the back of recorder; (NOT the terminal module ground connection) to ground the flexible metal conduit.

- Instruments not fitted with the optional internal on/off switch and fuse must have a disconnecting device such as a switch or circuit breaker conforming to local safety standards fitted to the final installation. It must be fitted near the instrument within easy reach of the operator and must be marked clearly as the disconnection device for the instrument.
- Remove all power from supply, relay and any powered control circuits and high common mode voltages before accessing or making any connections.
- Use cable appropriate for the load currents. The terminals accept cables up to 14AWG (2.5mm<sup>2</sup>).
- The instrument and all inputs and outputs conform to Mains Power Input Insulation Category II.
- All connections to secondary circuits must have basic insulation. After installation, there must be no access to live parts e.g. terminals.
- Terminals for external circuits are for use only with equipment with no accessible live parts,
- If the instrument is used in a manner not specified by the Company, the protection provided by the equipment may be impaired.
- All equipment connected to the instrument's terminals must comply with local safety standards (IEC 60950, EN601010-1).

#### ➤ NOTE:

To ensure maximum recorder performance, proper wiring installation practices must be followed. Failure to do so can result in a range of problems, from loss of configuration to component failure, caused by transmitted or radiated electrical noise. Proper consideration must be given to local noise sources and appropriate suppression steps taken to minimize any potential problems. Among the most common sources of noise are: Relays, SCRs, valve solenoids, electric motors, power line disturbance, wire-to-wire coupling, electrostatic discharge (ESD) and radio-frequency interference (RFI).

**To achieve the best results, the following notes should be considered:**

1. Low level signal wiring such as that associated with thermocouples, RTDs and current loops should always be kept separate from power and control output wiring.
2. Signal input wiring should be twisted pairs/triplets etc. The conductors should be stranded rather than solid in construction. All signal wiring should use ground-shielded wires or be routed through grounded conduit to minimize the effects of RFI and ESD.
3. Exceptional care should be taken when wiring to relay or solenoid coils, as large transients are produced when coils (or any other inductive loads like motors or arc welding equipment's etc.) are switched. This problem can be eliminated using suitable suppression devices across the coil. Coil transients can also be transmitted through the air, so the recorder itself should be mounted as far as possible from power control devices and/or wiring.
4. When line power is poorly regulated and / or subject to voltage surges or transients, consideration should be given to the use of a line conditioning/transient suppressing line power regulator. Process control motors, valves, relays and heaters should not be connected to the same power lines that are used for instrumentation.
5. The connection of the recorder to a proper safety earth ground is essential. Such a connection not only reduces the possibility of electric shock, but also provides the required return for the recorder line power filters.
6. All local electrical codes of practice must be followed when installing any instrumentation.
7. If wall or pipe-mounting to NEMA 4X (IP65) hose down standard is required, suitable cable glands must be used to prevent water ingress.

#### 4.1.2 Wiring diagram for recorder

##### **Check for proper Earthing**

Proper Earthing is necessary for best performance of the Recorder. Follow the steps mentioned below to check whether the Earthing given to the recorder is proper or not:

- Find out the Phase line of connection with the help of "Tester with Neon Lamp". When Neon Lamp glows, it is an indication of the phase line.
- Once Phase is found, the other hole which is in line of phase is the Neutral line.
- The third hole which is apparently bigger in diameter is the Earthing line.
- Now take the voltmeter with appropriate measurement range (normally 750VAC or higher) and put the probes into PHASE and NEUTRAL line and take reading.
- The voltage across PHASE and EARTH, and NEUTRAL and EARTH.
- The voltage between Neutral and Earth Should not be more than 6V. If by any chance it is more than 30V, it is a serious fault on earth line. And must be immediately be corrected.

**Proper Earthing is essential for safety of the personnel and for the proper functioning of the equipment.**

Note: If connecting the instrument in the panel, panel and recorder both should be at the same Earthing potential.

##### **Wiring diagram for 11" recorder:**

Loosen the captive screws on the chart plate fully. Open the chart plate. Ensure that the pen assembly is not damaged. You will find two PCBs in the recorder. One PCB (power supply) is fitted at the bottom of the box and another (sensor PCB) is fitted on the chart plate as shown in figure- 6. Refer to the following drawings to connect mains, battery and sensor to the recorder. If IP protection is opting for, please ensure that all the cables are passed through the glands and glands are tightened fully after completing the wiring.

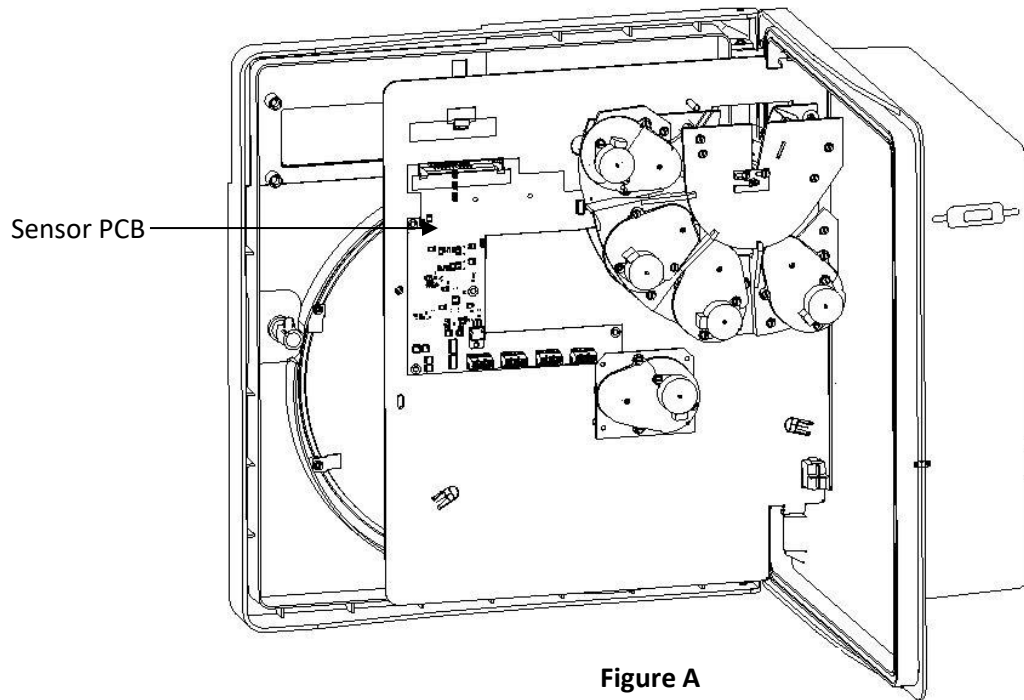

**Figure A**  
Open Chart Plate

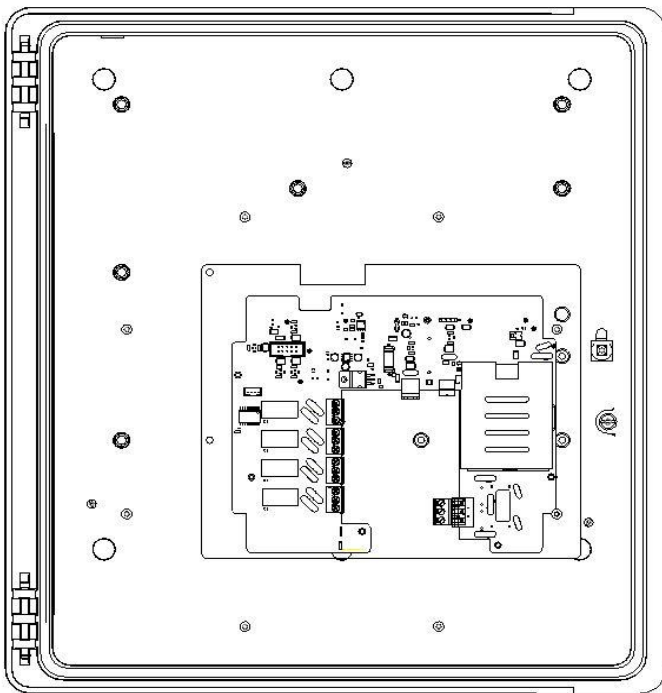

**Figure B**

Front view of base box with power  
supply PCB mounted on it

*Figure 6 – View of recorder after opening chart plate*

4.1.2.1 Connection of recorder with Main supply, Battery, Relay and Fuse

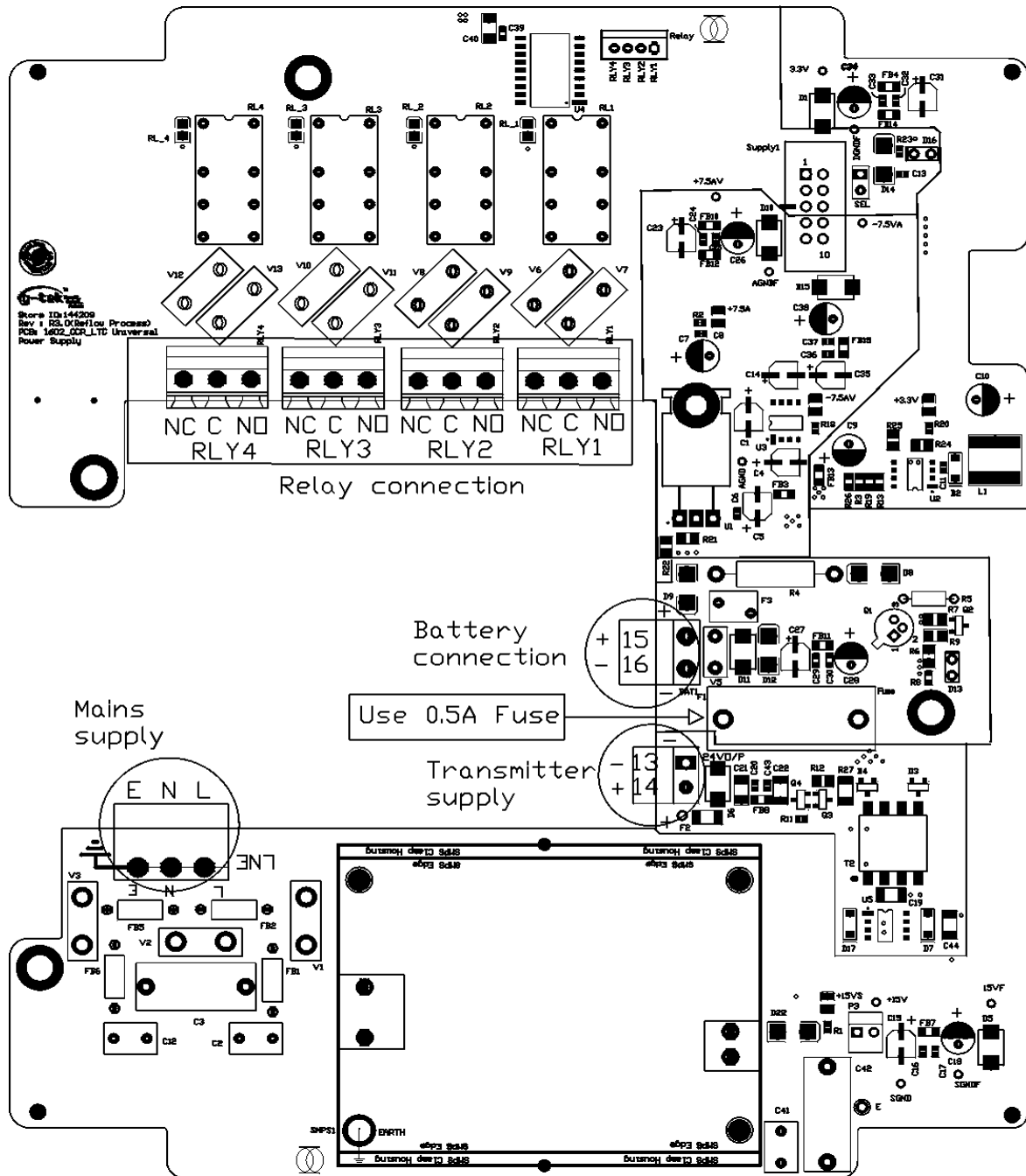

Figure A



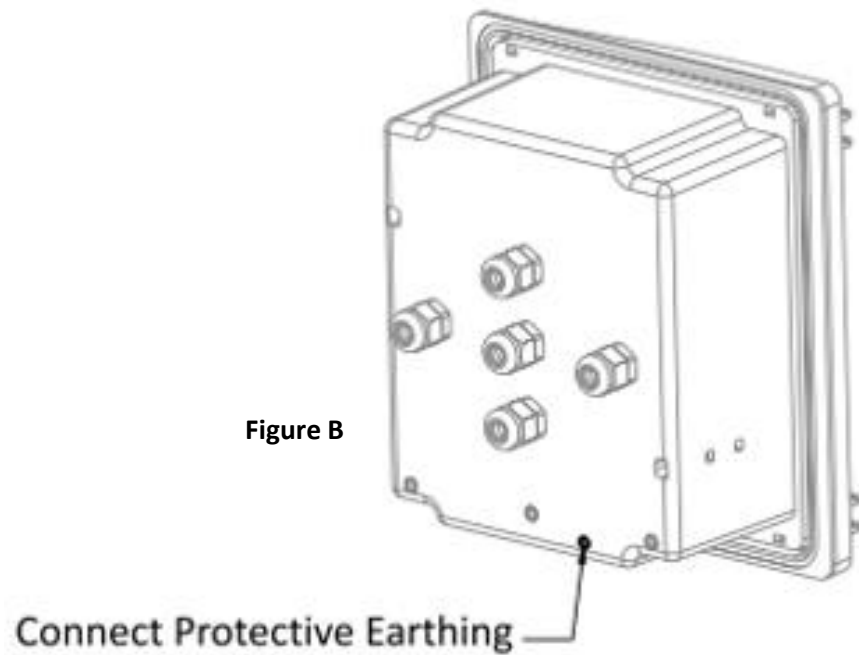

Figure 7 – Power Supply PCB

- The connection for Mains supply is shown in figure A. As per the figure the live, neutral & earth from the mains cord are connected to L, N & E respectively. Ensure that the bared ends of the mains cord are fully inserted into the mains connector and no loose/poor connection. Also connect the Earth wire of the cable to the Earthing terminal given on body of the recorder as shown in figure B.
- The connection of 12V DC battery is shown in figure- 6 Connect the '+' and '-' of 12V battery to the '+' and '-' terminal of the connector respectively.
- Relay connection provided for connecting alarm indicating devices like buzzer, hooter etc. in the industry, to indicate temperature variation above or below the set points as shown in above figure.

**Note:**

- \* Use 2.5sq.mm. Wire maximum
- \* Relay Contact ratings are 230VAC – 1Amp. Resistive.
- \* Use of appropriate snubber Circuit is recommended for

#### 4.1.2.2 *Sensor wiring*

To ensure maximum recorder performance, proper wiring installation practices must be followed. Failure to do so can result in a range of problems, from loss of configuration to component failure, caused by transmitted or radiated electrical noise. Proper consideration must be given to local noise sources and appropriate suppression steps taken to minimize any potential problems. Among the most common sources of noise are: Relays, SCRs, valve solenoids, electric motors, power line disturbance, wire-to-wire coupling, electrostatic discharge (ESD) and radio-frequency interference (RFI).

To achieve the best results, the following notes should be considered:

1. Low level signal wiring such as that associated with thermocouples, RTDs and current loops should always be kept separate from power and control output wiring.
2. Signal input wiring should be twisted pairs/triplets etc. and the conductors should be stranded rather than solid in construction. All signal wiring should use ground-shielded wires or be routed through grounded conduit. This minimizes the effects of RFI and ESD.
3. Exceptional care should be taken when wiring to relay or solenoid coils, as large transients are produced when coils (or any other inductive devices) are switched. This problem can be eliminated using suitable suppression devices across the coil. Coil transients can also be transmitted through the air, so the recorder itself should be mounted as far as possible from power control devices and/or wiring.
4. When line power is poorly regulated and / or subject to voltage surges or transients, consideration should be given to the use of a line conditioning/transient suppressing line power regulator. Process control motors, valves, relays and heaters should not be connected to the same power lines that are used for instrumentation.
5. The connection of the recorder to a proper safety earth ground is essential. Such a connection not only reduces the possibility of electric shock, but also provides the required return for the recorder line power filters.
6. All local electrical codes of practice must be followed when installing any instrumentation.

Please refer to the back panel of recorder to know the type of sensor input. For sensor wiring follow the steps mentioned below in figure 8. The Sensor PCB and the Sensor connector are shown in figure 9.

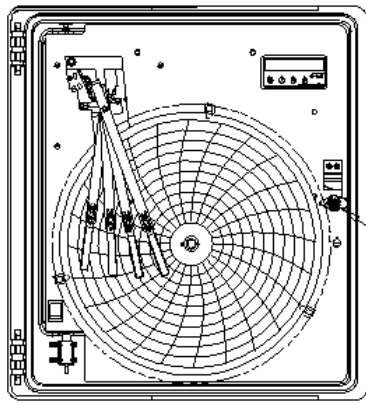

STEP 1

STEP 1  
Rotate the handle in anticlockwise direction to open the door of the recorder

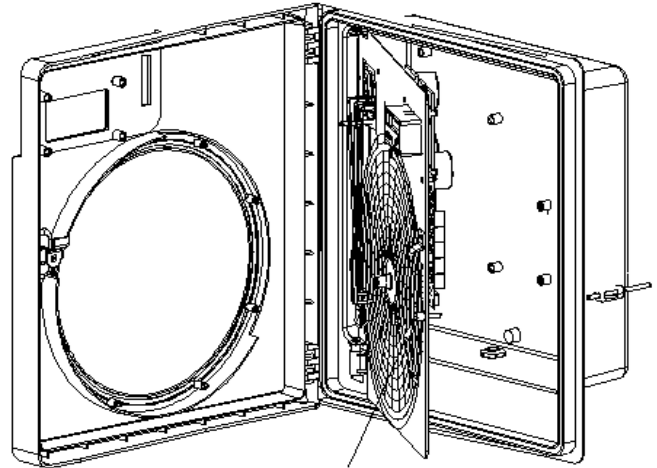

Loosen the captive screws

STEP 2

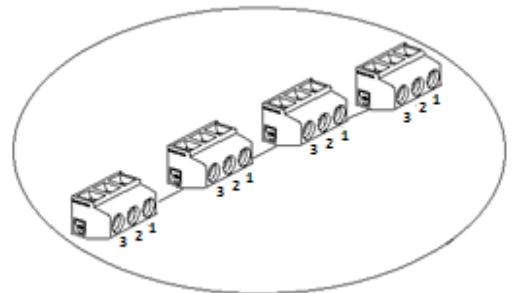
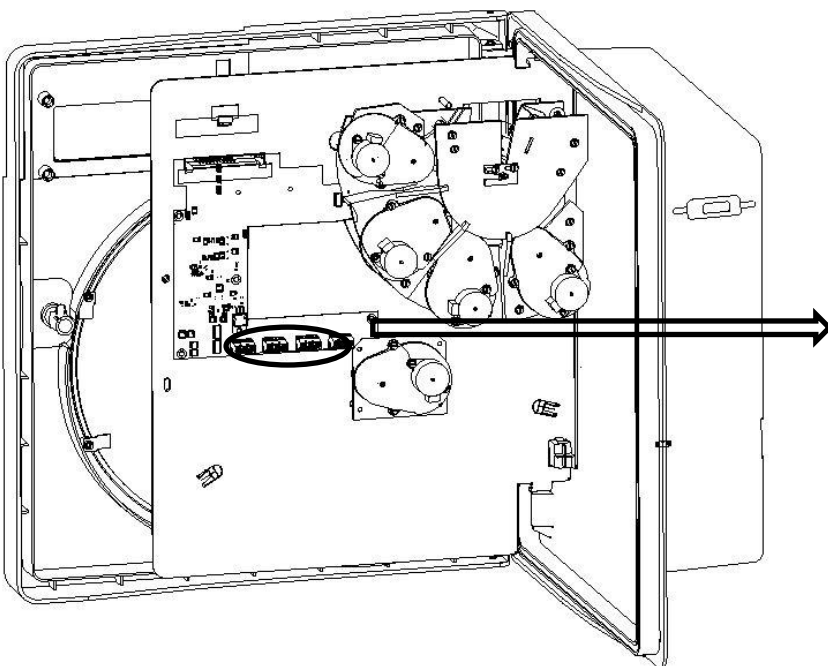

**Sensor Connector terminal**

- 1- (+) Red Wire
- 2- (-) White wire
- 3- (W) White wire

Step 3:  
Opened Chart plate and the Sensor connector

Figure 8 – Sensor wiring

4.1.2.3 Sensor wiring for different sensor types

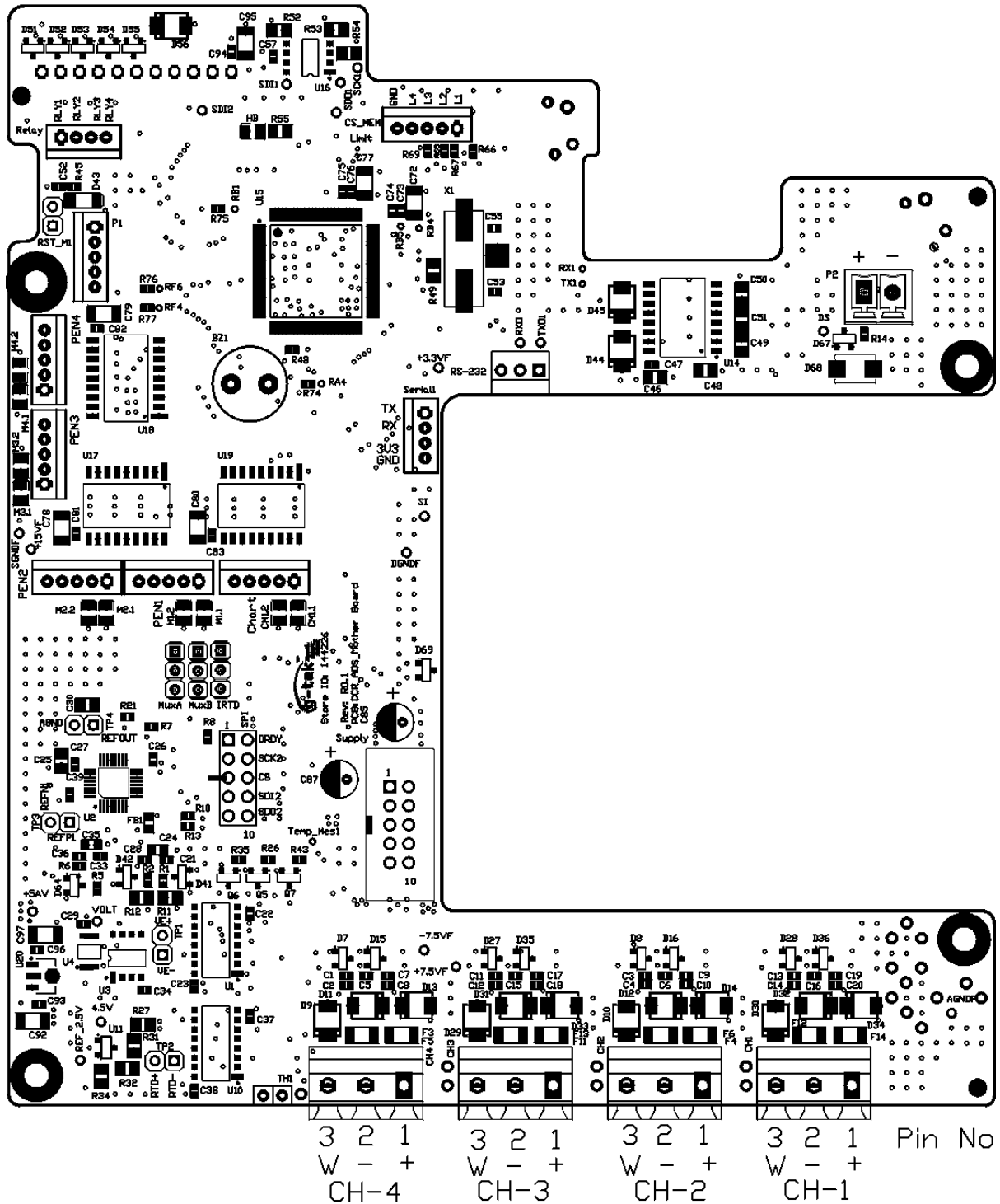

Figure 9 – Pin Descriptions of sensor connector

The Recorder can be connected and configured to operate with a variety of signal sources as thermocouple, RTDs, dc current, dc voltage etc. The sensor wiring for different sensors for 4 Pen recorders with display is shown as Table 2:

For wiring of different sensors, prefer following table.

Table 2 Sensor Wiring

Sensor Type	Pin numbers of connector		
	1	2	3
RTD (PT-100) 3-Wire	Red (+)	White (-)	White
RTD (PT-100) 2-Wire	Red (+)	White (-)	Short link between 2 and 3
Thermocouple	Positive (+)	Negative (-)	NC
mV	Positive (+)	Negative (-)	NC
mA	Positive (+)	Negative (-)	NC

Note:

1. Pin No 1 ,2,3 are shown in the above figure 9.
2. When wiring RTDs, lead length and diameter must be chosen such that lead length are equal and that each lead exhibits no more than 10 resistance between the recorder and the RTD (Pt-100).
3. For Input connections, high quality, low resistance contacts must be used which are suitable for dry operations.
4. The sensor wire connections mentioned in above table will remain same for all the channels.
5. Provide 50 Ohm External Shunt resistance between Pin No 1 & 2 while using 4-20 mA/0-20 mA.

Connecting Transmitter with recorder & other instrument using External Power Supply: -

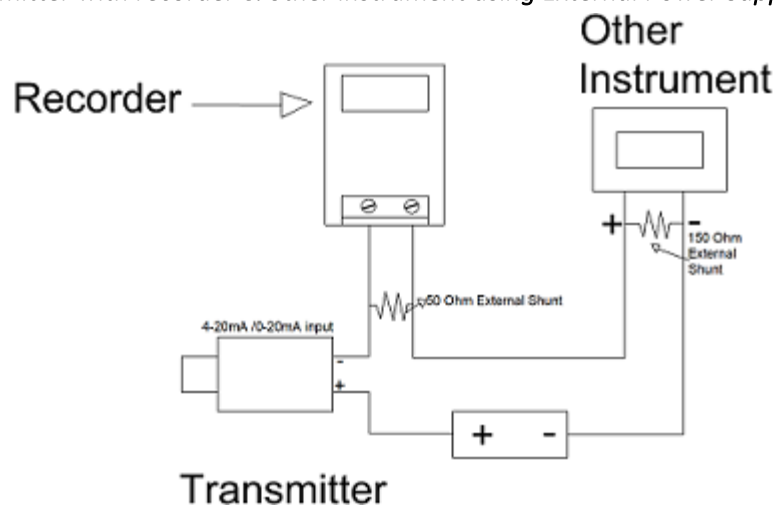

Figure 10 - Connecting Transmitter with recorder & other instrument using External Power Supply

The connection for 4-20 mA. / 0-20 mA. Input is shown in figure-11. For chart recorder, the shunt of 50 Ohms is externally supplied. If you want to connect more than one instrument in series, than chart recorder should be placed in such a way that not more than 150 Ohms of load resistance is added in the loop after chart recorder as shown in figure- 10. Connection of chart recorder with Transmitter and External Power Supply is as Shown in figure- 10.

**Connecting Recorder with Transmitter using Internal Transmitter Power Supply:**

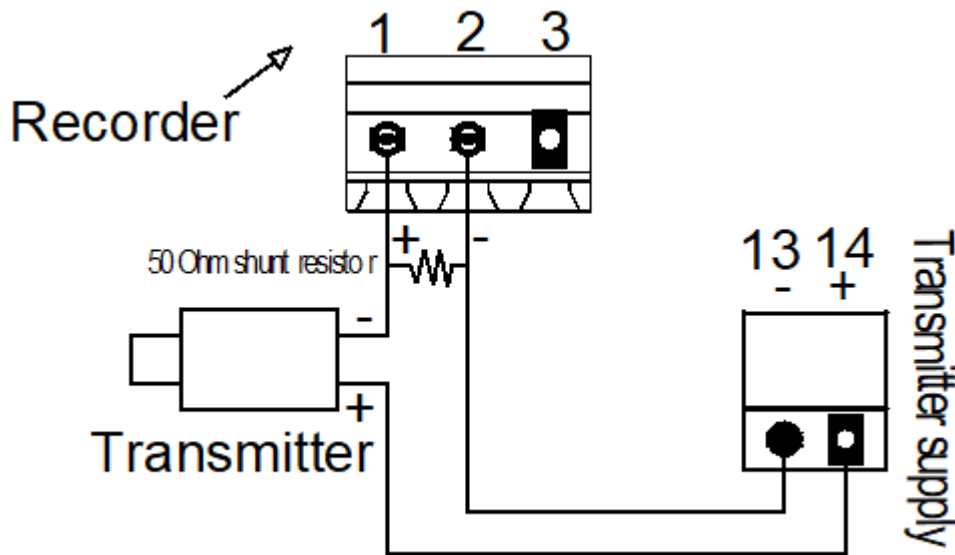

Figure 11 - Connection of Recorder with Transmitter and Internal Power Supply

**Internal Transmitter Supply**

Connection of Recorder with Transmitter and Internal Power Supply is as Shown in above figure- 11.

**Caution:**

A transmitter in a current loop must not be shorted. If it is, the transmitter power supply is essentially connected directly across the input shunt. In such a case, the shunt will almost certainly suffer damage.

## 4.2 FITTING THE PEN

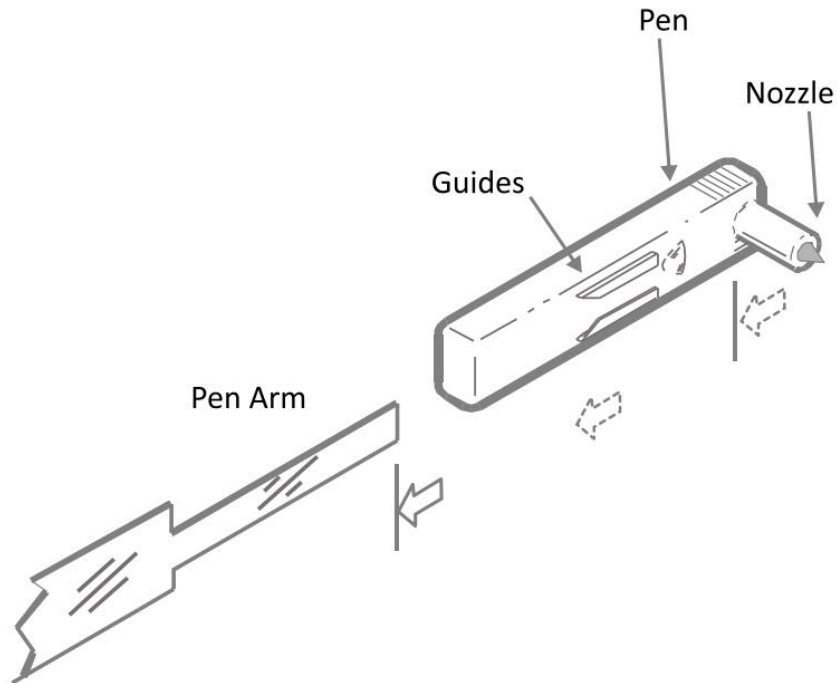

Figure 12 - Fitting / Replacing the Pen

### While fitting/ replacing the pen follow the steps:

**Step-1:** Slide the pen over pen arm until the tip of the arm passes through the guides and touches the nozzle.

**Step-2:** A new pen may have burrs or obstructions in the guides. Apply enough force to clear the guides or use sharp knife to clean the guide beforehand.

### Caution:

- Improper fitting of the pen may result in incorrect recording.
- An attempt to change the pen in Power On condition may result in damage to the recorder.

**Note:** It is recommended that the operator wear plastic gloves whilst handling pens to avoid ink contamination of the hands.

### 4.3 FITTING THE CHART

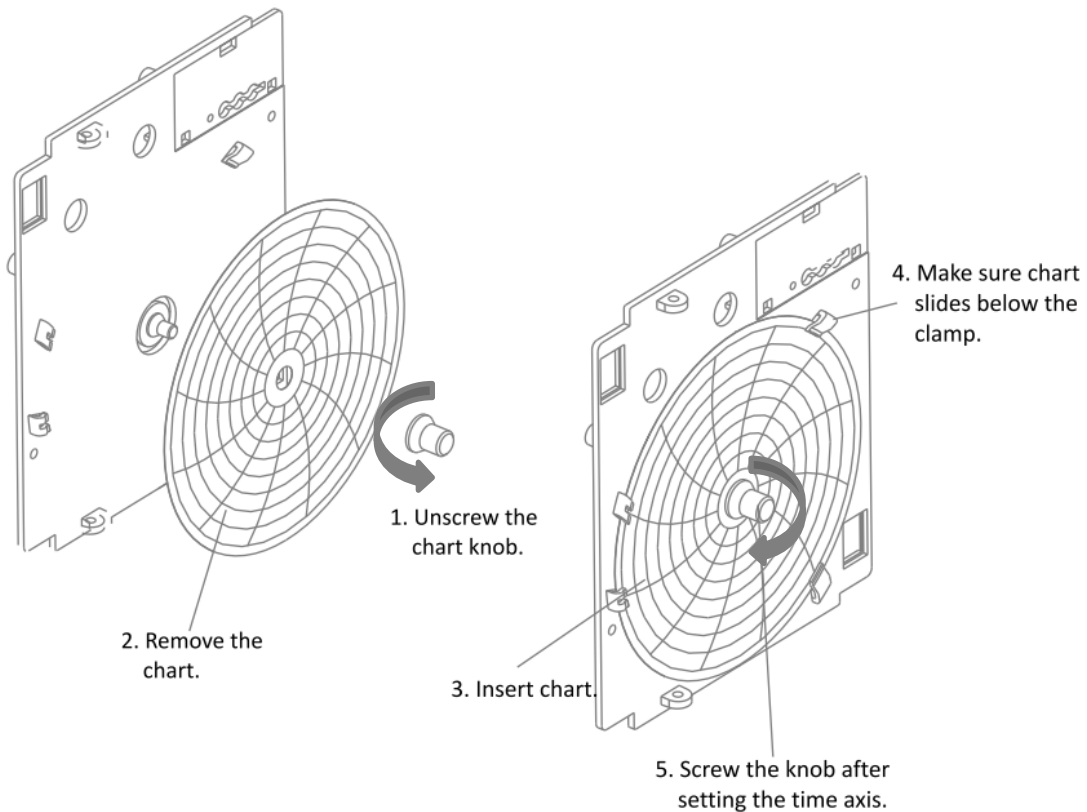

Figure 13 - Chart Fitting

#### To replace the chart, follow the steps:

- Open the door of the recorder.
- Unscrew the chart knob as shown in figure.
- Remove the chart.
- Insert the new chart.
- Screw the knob after setting time axis. Make sure that chart slides below the clamp as shown in figure.

### 4.4 REPLACE FUSE (BATTERY BACKUP)

#### Follow the steps given below to replace the fuses:

- Disconnect the recorder from the mains. This is very important to avoid shock hazard.
- Open the door of the recorder.
- Open the Chart plate.
- Use screwdriver to lever out the fuse holder.
- Replace the fuse with a new one of the proper rating (20mm, glass fuse, fast blow, 0.5A)
- Press the holder firmly back into place.



## 5 OPERATION

After the proper wiring is done, pen and chart fitted properly, power on the recorder. The Display will show “G-tek Co” and all pens will move towards the zero-scale position of the chart. After they reach the zero-scale position of the chart, it stops there. After a while pens will move to the position on the chart as per the parameter values and the parameter values will also be displayed on the display. User can reconfigure the parameters here by going into programming menu (Refer Programming section).

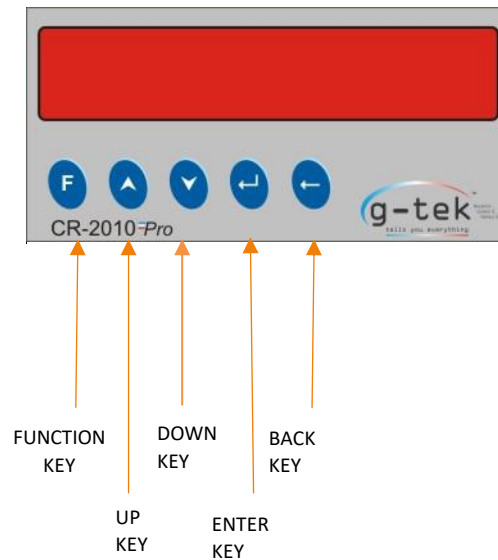







Figure 14 - Four Pen Recorder Front Panel





### **KEYS:**

There are five multifunction keys are available on the front panel of the chart recorder to configure the different parameters. The functions of these keys are described as under:

-  This key is used to enter the main menu sequence as well as come out from the main menu.
-  This key is used to increment the digits or go to the next parameter.
-  This key is used to decrement the digits or go back to the previous parameter.
-  This key is used to save the parameter values, to enter a menu/submenu.
-  Using BACK key user can go back to the previous/out of function menu

## 6 CONFIGURATION

Usage of Keys:

-  To enter in the function menu for modification or to come out from the function menu/submenu.
-  Up Key is used to increment the parameter value. It is also used to go to the next parameter/sub-menu.
-  Down Key is used to decrement the parameter value. It is also used to go back to the last parameter/sub-menu.
-  To store the parameter value and use to enter in the function for modification.
-  To Return from the Sub-Menu.

### 6.1 CONFIGURABLE ITEM

Table 3 Configurable Items

Sensor Types	1) RTD (Pt-100) 2) TC - J 3) TC - K 4) TC - C 5) TC - R 6) TC - S 7) TC- T 8) TC- B 9) TC- E 10) TC- N 11) 4-20mA 12) 0-20mA 13) -1000.0 to + 1000.0mV & 0.0 to +1000.0mV 14) -5000.0 to + 5000.0mV & 0.0 to +5000.0mV
Channels to scan	The parameter value for all channel, digital inputs and digital outputs will be display with rolling action. Also scan channel with Freeze action.
Range Low	The minimum value shown on display when process inputs like 0-1 Volt, 0-20 mA & 4 - 20mA are at 0V, 0mA & 4mA respectively.
Span	The difference between maximum & minimum value used for process inputs.
Offset	A small correction may be required when actual sensor is connected to the chart recorder. This is a mathematical value which is directly added to the reading.
Multiplier	A value to remove any scale error. This is a mathematical value which is directly multiplied to the reading. Displayed reading = (reading x multiplier) + offset
Resolution	Measure the accuracy of the output value
Set point High	The upper limit of value, after which relay will be toggled
Set point Low	The lower limit of value, after which relay will be toggled
Chart Zero	Minimum value of the output which is considered as a zero scale on chart

Chart Span	Chart span is defined as the difference between Chart Full Scale and Chart Zero
<b>Communication Parameters:</b>	
Device Address	Address of chart recorder for communication with computer
Saving Configuration	Channel parameters

The chart recorder can be Configured using front panel Keyboard. User can enter the configuration. The following figure shows the main menu sequence:

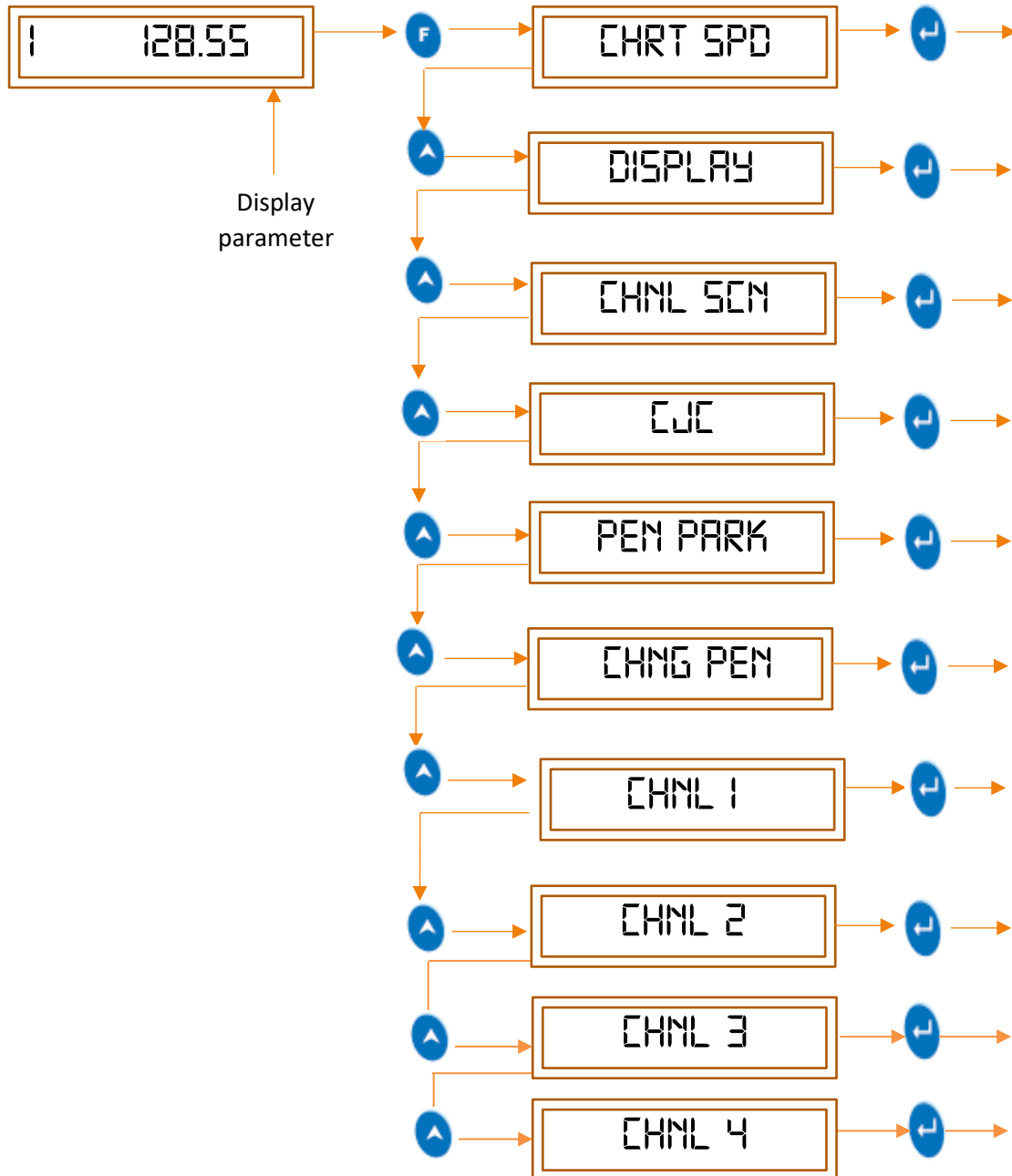

Figure 15 - Main menu display

## 6.2 FUNCTIONS

### 6.2.1 Chart Speed

In the chart speed menu, we can adjust the speed of chart to complete one cycle in hour and minute mode. If user have set speed in hour mode at installation time, then "HR IN ST" option seen in chart speed menu. If user have set speed in minute mode at installation time, then "MN IN ST" option seen in chart speed menu.

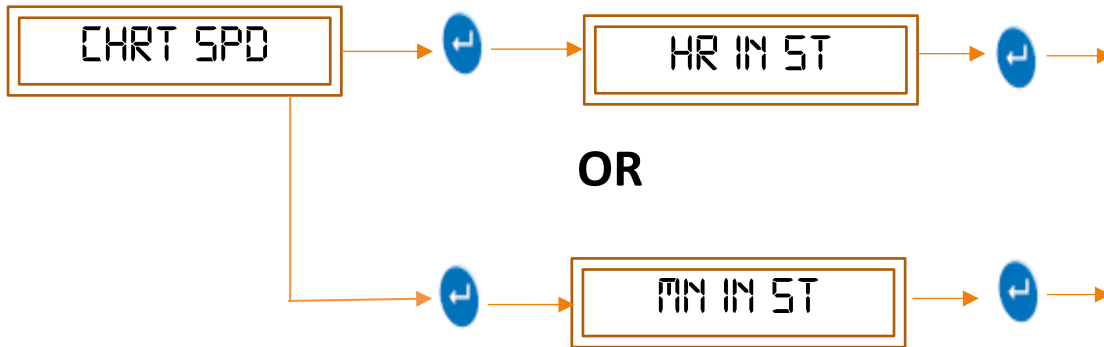

Figure 16 - Chart speed

#### 6.2.1.1 Hour in step/Minute in step

If Chart speed is set in "hour in step" mode, one hour is counted for single count. Count range is 1 to 255. If Chart speed is set in "minute in step" mode, 15 minutes are counted for single count.

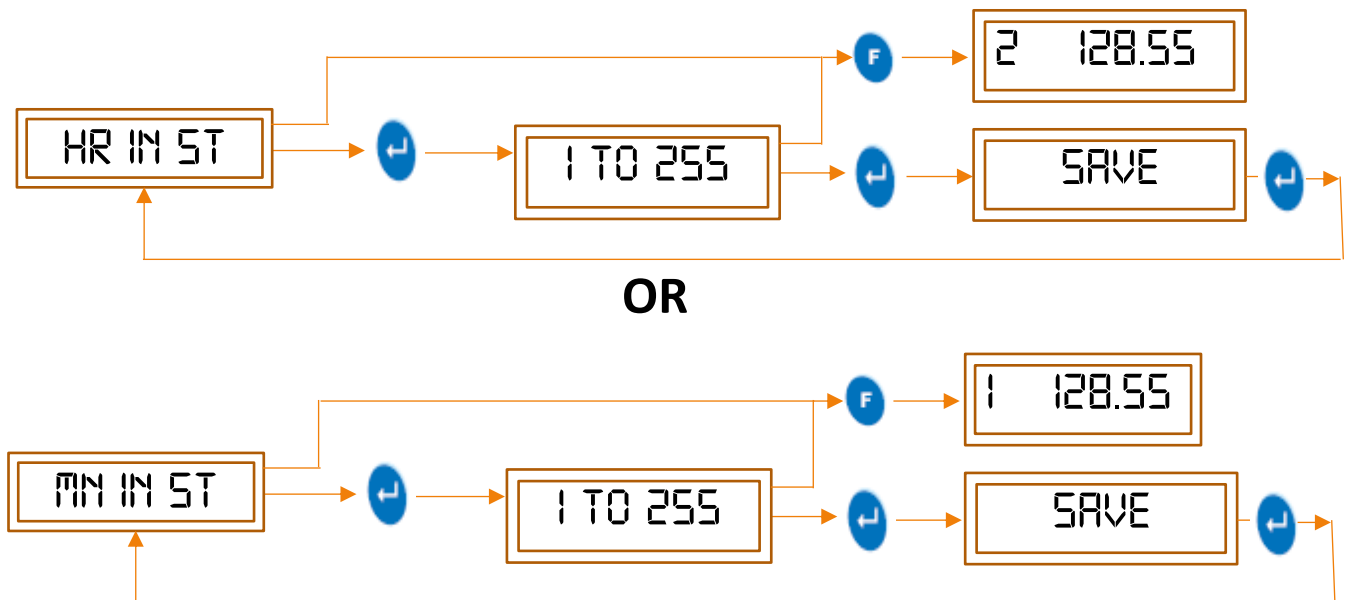





Figure 17 - Hour/Minute option

- Note: -
-  To increase the digit value
  -  To decrease the digit value
  -  To come out from functions/ sub menu

### 6.2.2 Display Setting

To watch the current data of different sensor, channels on led display then we should follow the procedure shown in figure-18. By using the display setting we can set the fix panel to watch continuously or we can set the group of panels to watch on led display which shows data on led display one by one with time gap. Pen has no effects of this display settings. All pen moves according their channel readings. Freeze channel does not effect on pen movements.

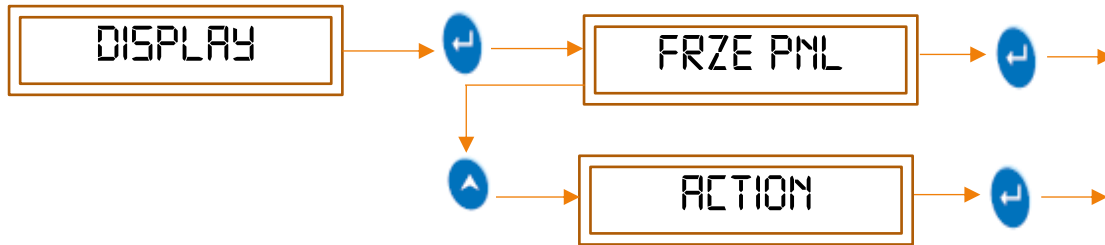

Figure 18- Display Setting

#### 6.2.2.1 Freeze panel

Use to select the panel and as on selected display action it will be display continuously or in rolling manner. To set freeze panel, follow the procedure shown in figure-19.

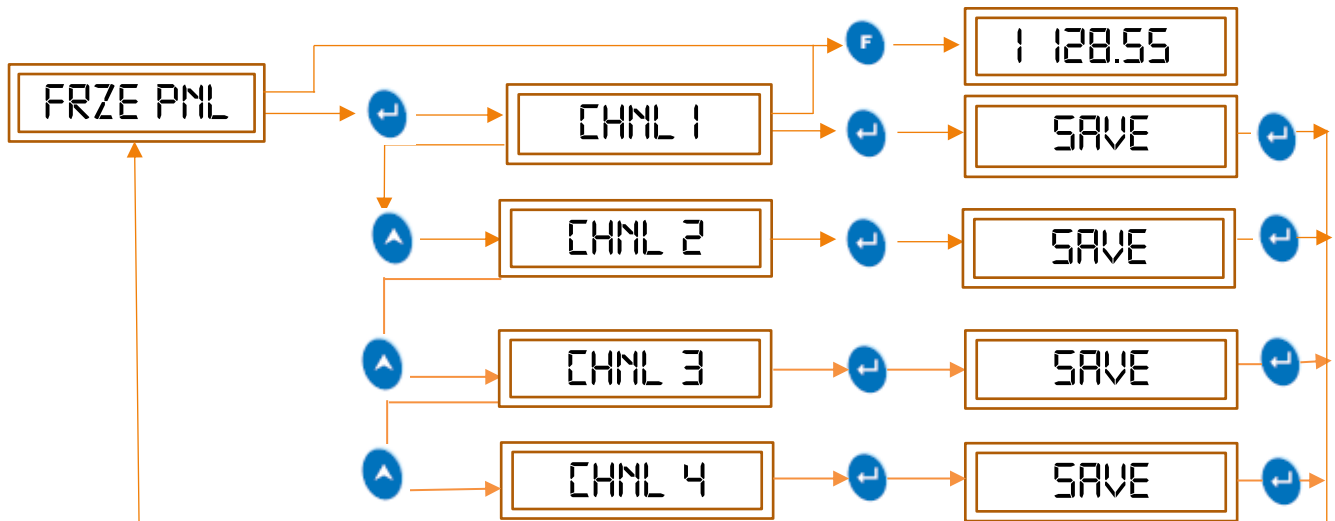

Figure 19 - Freeze Panel

#### 6.2.2.2 Action

By using the Action menu for display setting of chart recorder we can set the display continuously freeze or rolling to watch the current data from sensors up to selected panel.

To set display action follow the mention procedure shown in figure-20.

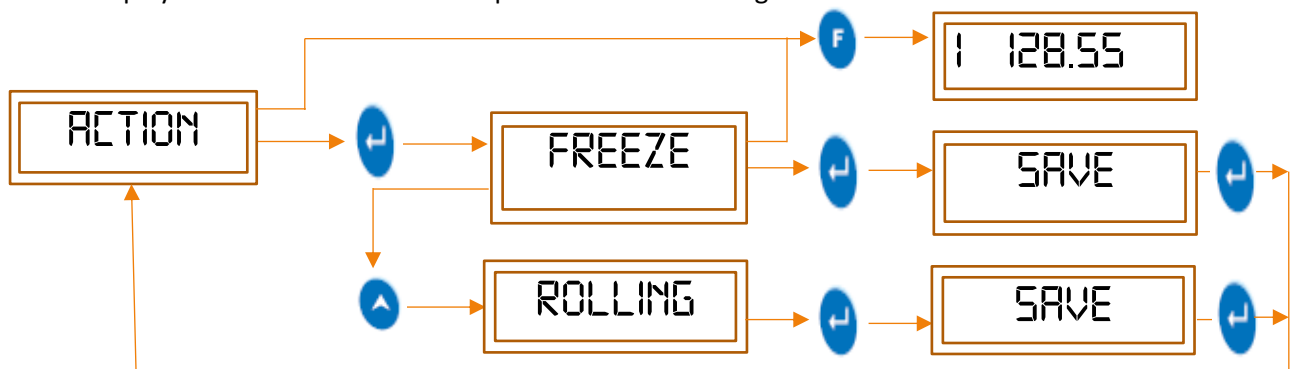

Figure 20 - Action (Display)

### 6.2.3 Channel Scan

This functionality will allow to skip the output data from four channels, it will not scan that channel even if sensor is connected on channel connector and will give output “skip” on display.

After entering to any channel, user have option “ON” or “SKIP” channel using up-down key.

Pen related to skipped channel will moves to the full scale on chart and does not show readings on chart.

To set the channel skip, follow the procedure shown in figure- 21. by pressing the appropriate buttons given in the front panel of the chart recorder.

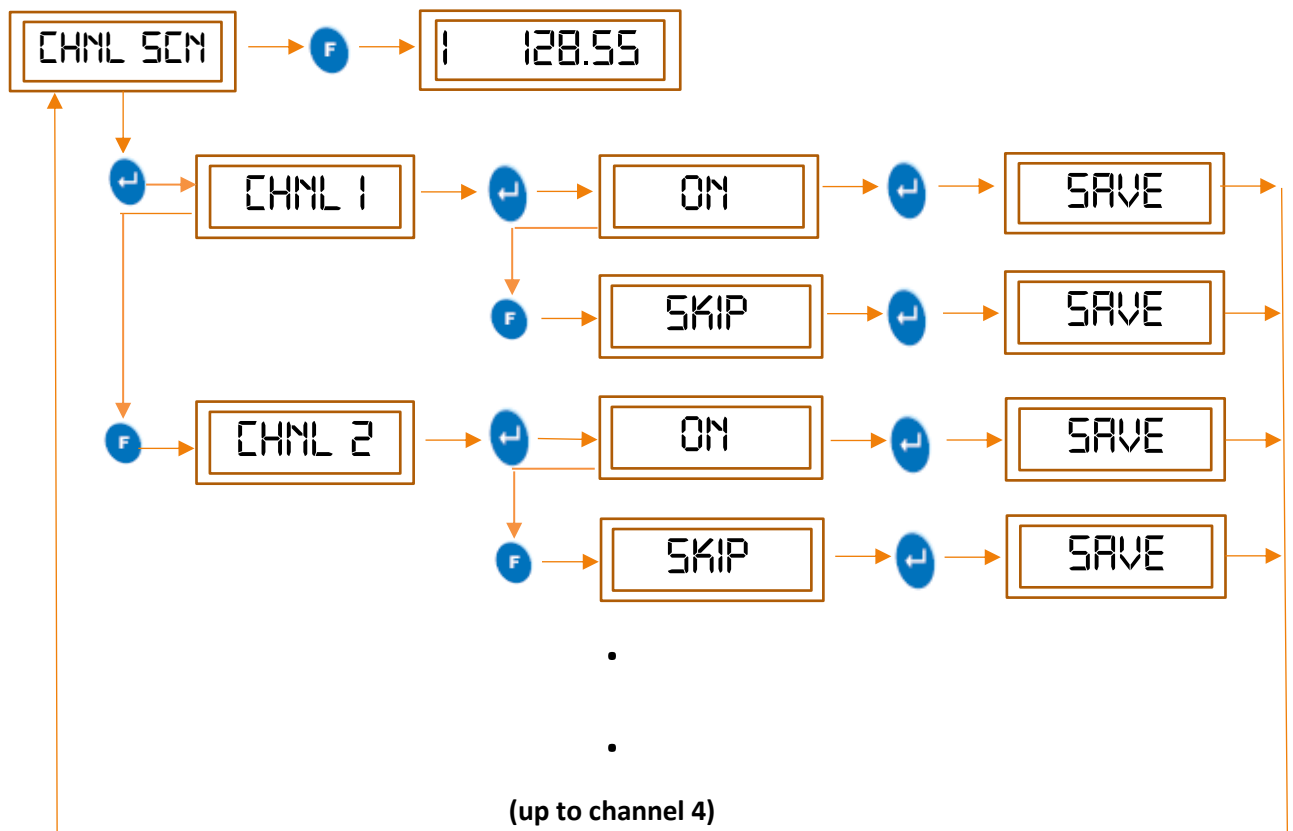

Figure 21 - Channel Skip

### 6.2.4 CJC

#### 6.2.4.1 Offset

A small correction may be required when actual sensor is connected to the device. To set offset for temperature reading, a mathematical value is directly added to the reading coming on led display with the reference value which we consider as an accurate value coming on other display device or machine. Pen is also moving according to final value after offset added.

#### 6.2.4.2 Multiplier

Sometime a major correction, may be required for temperature when actual sensor is connected to the device. A mathematical value expects zero is directly multiplied to the reading coming on led

display to get the specific output on same led display. Pen plot the chart according to final multiplied value which is displayed.

To set Offset/ Multiplier for temperature follow the procedure shown in figure-22 by pressing the appropriate buttons given on the front panel of the chart recorder.

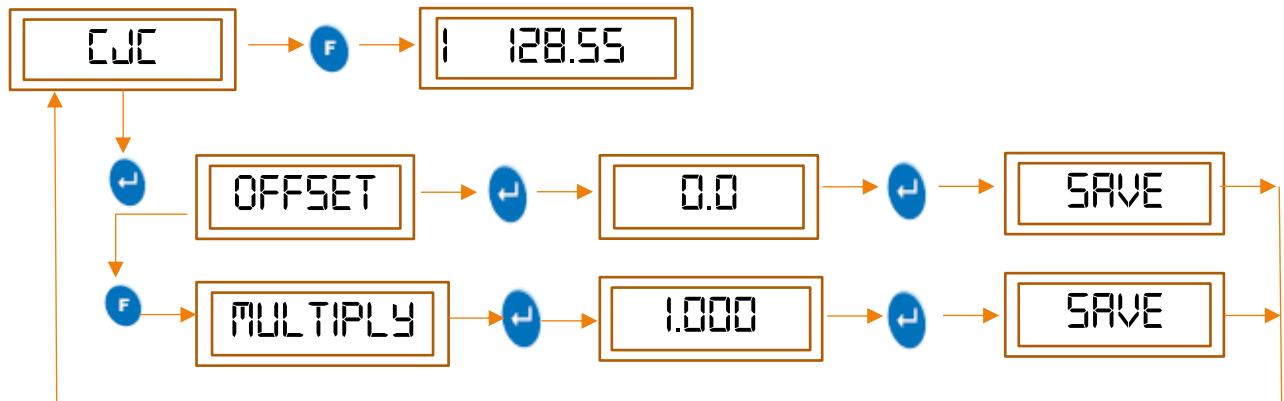

Figure 22 - CJC

### 6.2.5 Pen Park

Pen park feature used to change the pen position to full scale from current reading position.

#### 6.2.5.1 Park All Pen

In Pen park, when we choose all pen, all 2 pens will be shifted to the full-scale position. Led display continue showing the current reading. Pen remain on full scale for 2 minutes. After 2 minutes, again all pens come back to the current reading position.

#### 6.2.5.2 Park Pen 1

In pen park, if we set pen 1, pen 1 will be shifted to full-scale position. Channel 1 on led display continue showing channel 1 reading. Other pen remains on their current reading position. When we select reset in pen park menu in pen 1.

#### 6.2.5.3 Park Pen 2

Same as Describe in Type of Functions [6.2.5.2 Pen 1](#).

#### 6.2.5.4 Park Pen 3

Same as Describe in Type of Functions [6.2.5.2 Pen 1](#).

#### 6.2.5.5 Park Pen 4

Same as Describe in Type of Functions [6.2.5.2 Pen 1](#).

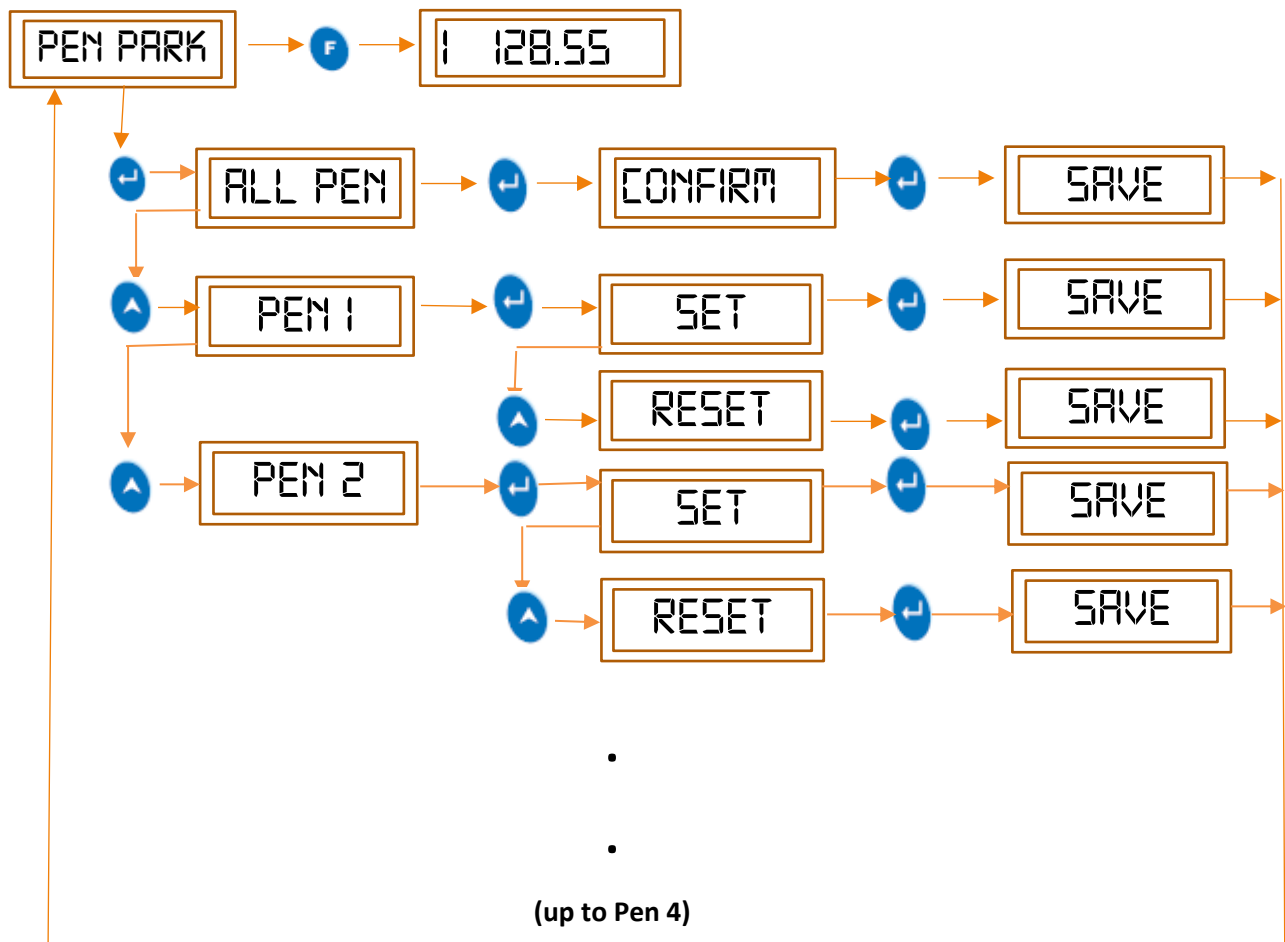

Figure 23 - Pen Park

### 6.2.6 Change Pen

Change pen feature used when user wants to change the pen. Pen moves to its fix position from current position. So, user can easily remove pen and attach new pen. Once pen reached its fix position, all the operations will be stopped, and display will be blinked with "restart". After changing the pen, user should be restarting the device.

#### 6.2.6.1 Change All Pen

In change pen, when we choose all pen, all 2 pens will be spread on chart with different angle. So, user can easily change the pen. When all pen reached their position, all operation will be stopped. Display will be blink with "restart". After changing the pen, user should be restarting the device.

#### 6.2.6.2 Change Pen 1

In change pen, when we choose pen 1, pen 1 will be shifted on its fix set position on chart. When pen 1 reached its position, all operation will be stopped. Display will be blink with "restart". After changing the pen, user should be restarting the device.

#### 6.2.6.3 Change Pen 2

Same as Describe in Type of Functions [6.2.6.2 Pen 1](#).



#### 6.2.6.4 Change Pen 3

Same as Describe in Type of Functions [6.2.6.2 Pen 1](#).

#### 6.2.6.5 Change Pen 4

Same as Describe in Type of Functions [6.2.6.2 Pen 1](#).

To set the change pen position for a single pen or all pen, then follow the procedure shown in figure-24 by pressing the appropriate buttons given in the front panel of the Chart recorder.

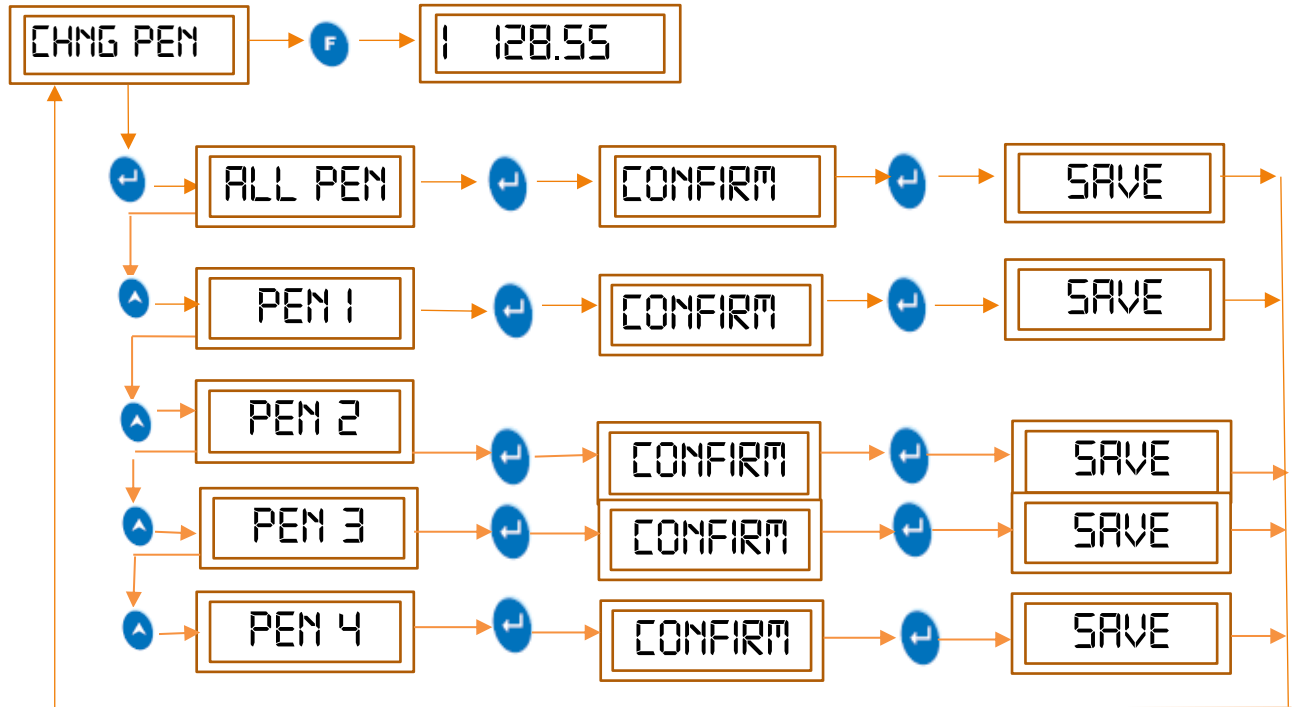

Figure 24 - Change Pen

#### 6.2.7 Channel 1

There are 2 input channels and 2 pens available for the user to configure and use. Thus, user can select any of the channel and can set the below mentioned parameters for it. There are 10 various parameters in each channel, but each channel has its different parameter values according to its use decided by user. Those parameters of every channel discussed below in detail.

To set this parameter then follow the procedure shown in figure-25 by pressing appropriate key of chart recorder.

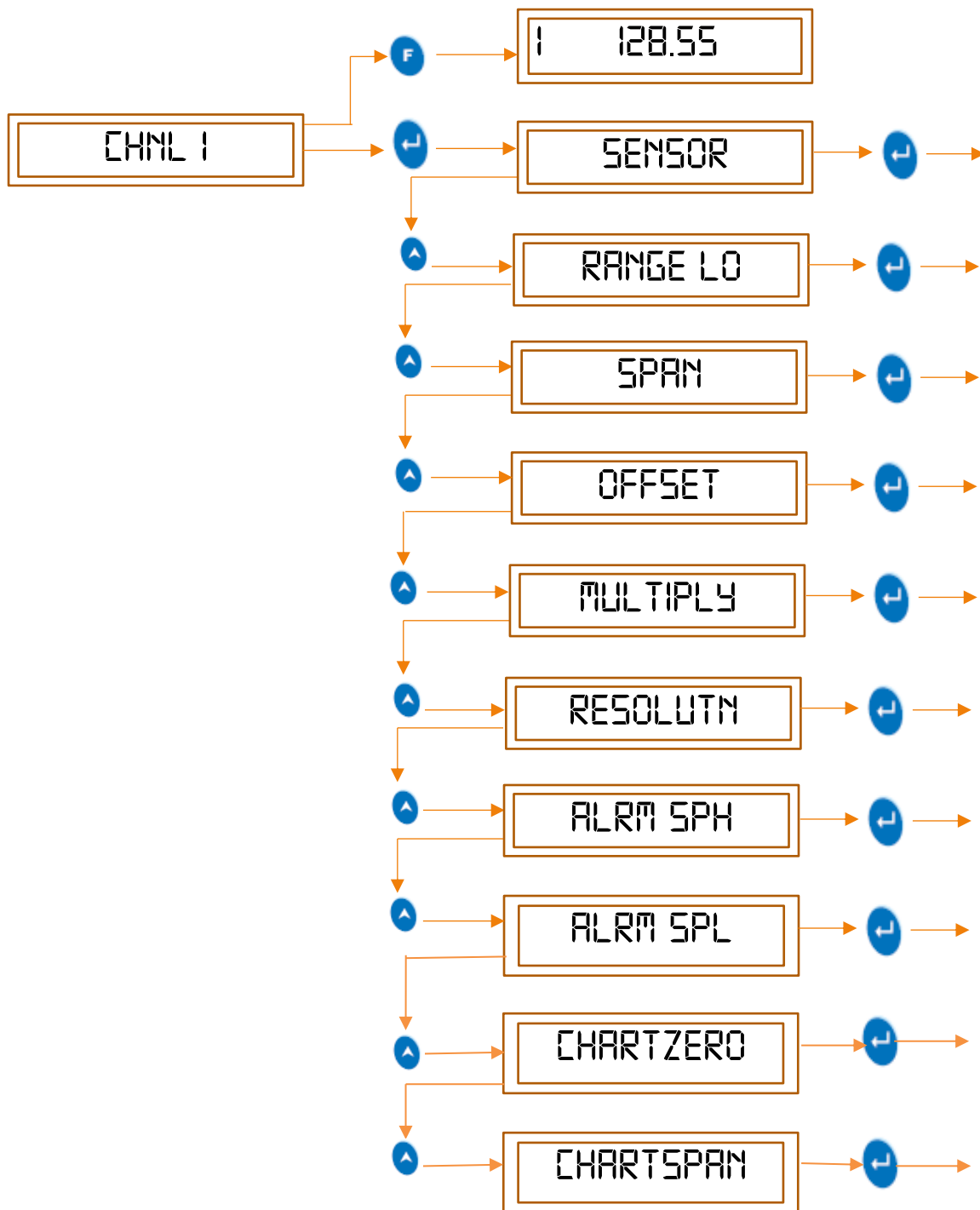

Figure 25 - Channel Configuration

### 6.2.7.1 Sensor

Three types of sensor inputs are being accepted by the chart recorder.

#### 6.2.7.1.1 RTD

It is Resistance Temperature Sensor. The sensor name is PT100.

A platinum resistance temperature detector (RTD) is a device with a typical resistance of 100  $\Omega$  at 0°C. It consists of a thin film of platinum on a plastic film. Its resistance varies with temperature and it can

typically measure temperatures up to 750 °C. The relationship between resistance and temperature is relatively linear as shown below for a sample 100 Ω RTD.

# PT100



Figure 26 - RTD Sensor

## 6.2.7.1.2 Thermocouple

There are total 9 types of thermocouple input the Chart Recorder accepts as listed under.

- ❖ TC-J  
It is made up of iron (+ve electrode) & constantan (-ve electrode). It operates over the temperature range of (-200) to (1200) C temperature. Its sensitivity is 50  $\mu\text{V}/\text{C}$ .
- ❖ TC-K  
It is made up of chromel (+ve electrode) & alumel (-ve electrode). It operates over the temperature range of (-200) to (1372) C temperature. Its sensitivity is 41  $\mu\text{V}/\text{C}$ .
- ❖ TC-C  
It is made up of tungsten (+ve electrode) & rhenium (-ve electrode). It operates over the temperature range of (0) to (2300) C temperature. Its sensitivity is 46  $\mu\text{V}/\text{C}$ .
- ❖ TC-R  
It is made up of platinum (+ve electrode) & rhodium (-ve electrode). It operates over the temperature range of (0) to (1750) C temperature. Its sensitivity is 36  $\mu\text{V}/\text{C}$ .
- ❖ TC-S  
It is made up of platinum & rhodium (+ve electrode) & platinum (-ve electrode). It operates over the temperature range of (100) to (1750) C temperature. Its sensitivity is 43  $\mu\text{V}/\text{C}$ . Mainly used for calibration for melting point of gold.

- ❖ TC-T  
It is made up of copper (+ve electrode) & constantan (-ve electrode). It operates over the temperature range of (-200) to (400) C temperature. Its sensitivity is 32  $\mu\text{V}/\text{C}$ . Mostly used in vacuum furnaces.
- ❖ TC-B  
It is made up of platinum (+ve electrode) & rhodium (-ve electrode). It operates over the temperature range of (200) to (1800) C temperature. Its sensitivity is 52  $\mu\text{V}/\text{C}$ .
- ❖ TC-E  
It is made up of chromel (+ve electrode) & constantan (-ve electrode). It operates over the temperature range of (-100) to (1000) C temperature. Also used for measuring low temperature, cryogenics (-110) to (140) C. Its sensitivity is 68  $\mu\text{V}/\text{C}$ .
- ❖ TC-N  
It is made up of nicrosil (+ve electrode) & nisil (-ve electrode). It operates over the temperature range of (-200) to (1300) C temperature. Its sensitivity is 39  $\mu\text{V}/\text{C}$ .

#### 6.2.7.1.3 Process Inputs

There is a total of 6 types of process inputs the recorder accepts

- 4-20 mA
- 0-20 mA
- Unipolar 1 Volt
- Bipolar 1 Volt
- Unipolar 5 Volt
- Bipolar 5 Volt

One of the examples of these process input is the Vibration sensor. The 4-162 vibration sensor is a compact, well-protected industrial accelerometer, giving a process output of 4-20mA proportional to various vibration ranges in terms of velocity RMS.

The 4-162 is intended for use as a direct input of vibration levels into many kinds of control and data acquisition systems, however it can be used with a trip amplifier or suitable display as a standalone unit.

Unipolar voltages include only one positive voltage for logic 1. That is unipolar 1 volt, 5 volt gives 1 volt, 5 volts output respectively for logic 1 and 0 volt for logic 0.

Whereas, bipolar voltages give output in form of positive and negative voltages. Bipolar 1 volt, 5 volt gives output +1-volt, +5 volt for logic 1 respectively and gives -1 volts, -5 volt for logic 0 respectively.

To select sensor as RTD/ Thermocouple/ Process inputs then follow the below mentioned procedure by pressing the appropriate buttons given on the top panel of the chart recorder.

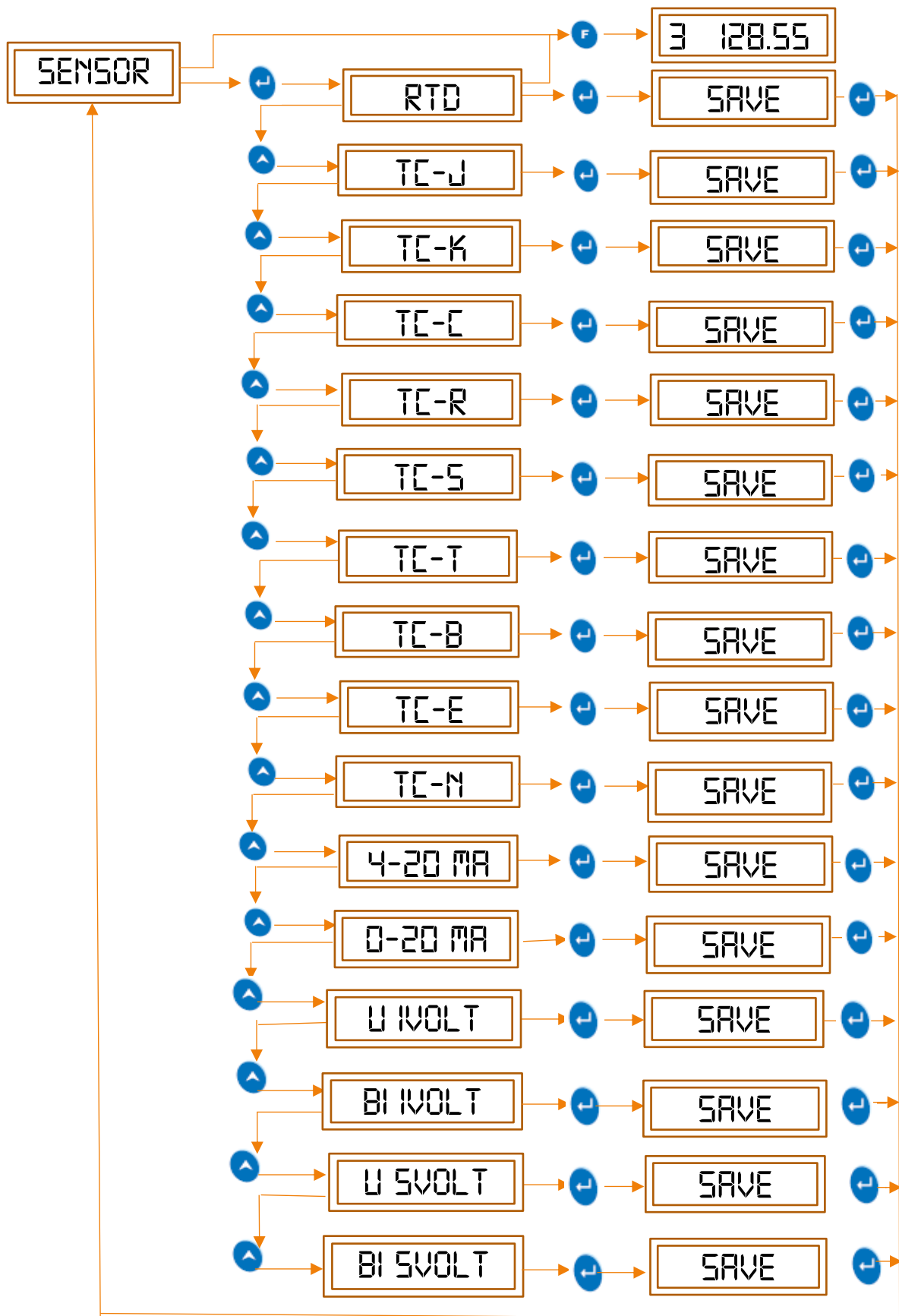

Figure 27 - Sensor Selection

### 6.2.7.2 Range Low

This feature is used for selecting the minimum value of the output that should be displayed on the led display or plotted on the chart is measured by the sensor.

For example:

If the user wants to measure the percentage of pressure of gases in the pressure valve, then then user needs to display the output in range of 0 to 100 %. So, here the range low should be set as 0 by the user.

Now, for the above case if the user wants to just measure the percentage of pressure if gone above 50% that is 50-100% then in this case the user should be set the value of range low as 50.

User can set the range low values anywhere between -3276.8 to 3276.7.

To set the Range Low for single channel then follow the procedure shown in figure- 28 by pressing the appropriate buttons given in the front panel of the chart recorder.

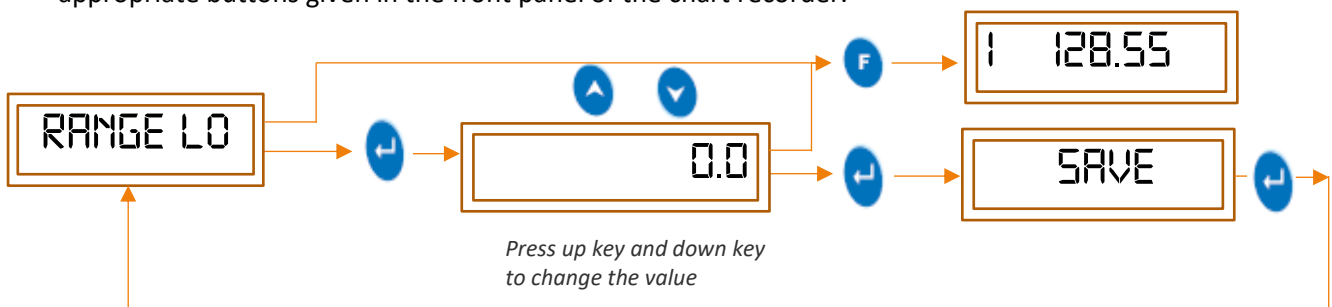

Figure 28 - Range Low Selection

### 6.2.7.3 Span

Span is the total range of values that a user wants to measure.

Span value indicates the total interval of which all the output values will be displayed.

For example:

If the user wants to measure the percentage of pressure of gases in the pressure valve, then user needs to display the output in range of 0 to 100 %. So, here the span should be set as 100 by the user. Span = (100-0).

Now, for the above case if the user wants to just measure the percentage of pressure if gone above 50% that is 50-100% then in this case the user should set the value of span as 50. Span = (100-50).

User can set the Span value anywhere between -3276.8 to 3276.7.

To set the span for a single channel then follow the procedure shown in figure- 29 by pressing the appropriate buttons given in the front panel of the chart recorder.

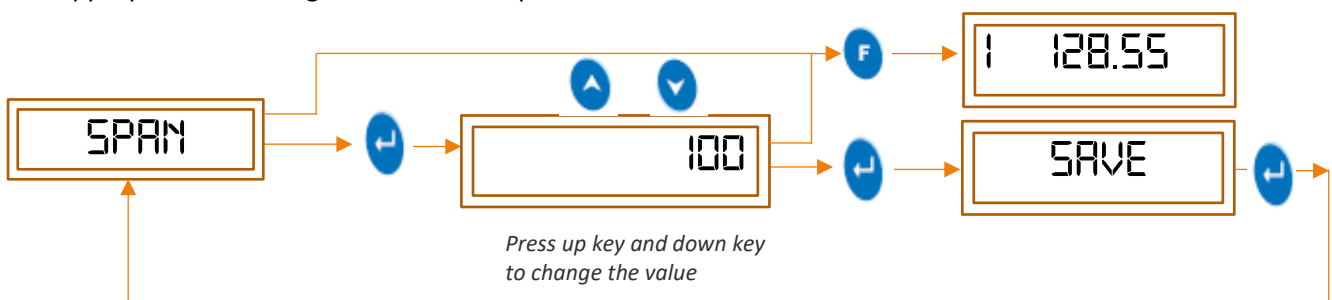

Figure 29 - Span Selection

#### 6.2.7.4 Offset

Offset is the amount of deviations that occurs in the output due to calibration errors of the sensor.

Thus, if there are deviations in the output compared to the expected output, offset value should be set appropriately to null the effect of deviation.

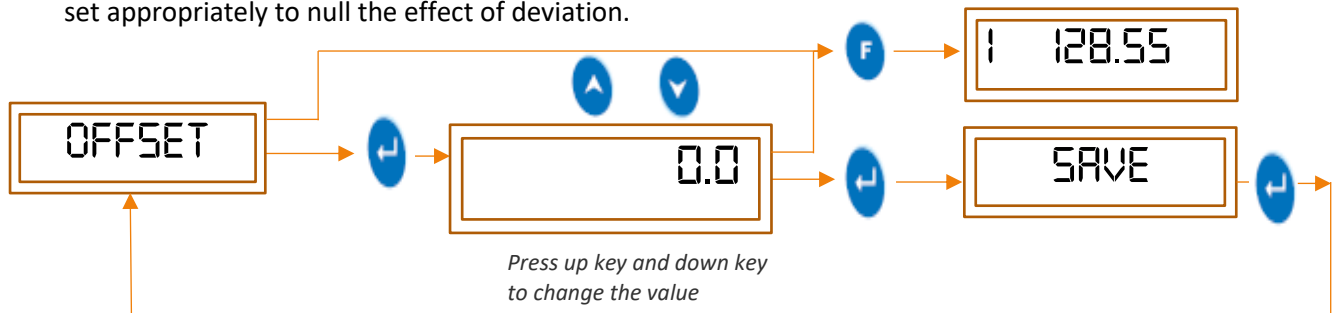

Figure 30 - Offset Selection

#### 6.2.7.5 Multiplier

Multiplier is a function given for the user flexibility. If the user wants to observe the output in the range other than the actual output range, multiplier value should be set.

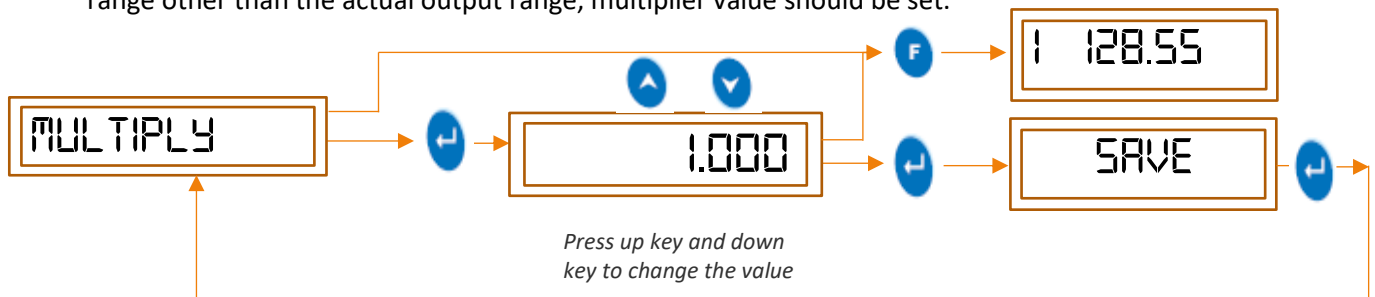

Figure 31 - Multiplier Selection

#### 6.2.7.6 Resolution Decimal Place

This is the measure of the accuracy of the output value. It is the measure of number of digits that user wants to include in the output display.

For example:

If the output is 2.301 then according to user, he can set the display output.

If Resolution is kept 0 then output is 2

If Resolution is kept 0.1 then output is 2.3

If Resolution is kept 0.01 then output is 2.30

If Resolution is kept 0.001 then output is 2.301

If Resolution is kept 0.0001 then output is 2.3012

To set the Resolution Decimal Place for a single channel then follow the procedure shown in figure-32 by pressing the appropriate buttons given in the front panel of the chart recorder.

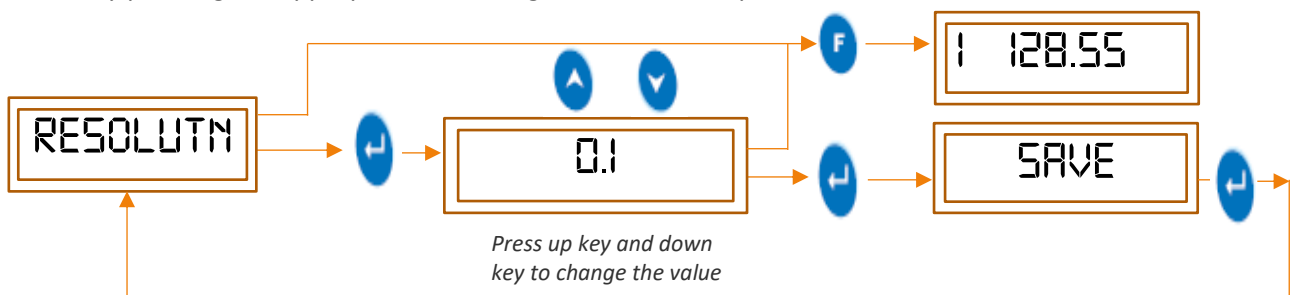

Figure 32 - Resolution Decimal Place

### 6.2.7.7 Set Point High

In this parameter, we should set the value to alert us whenever device reading goes higher than the set value, and that value should be set from -3276.8 to 3276.7

To set the Alarm Set point High for a single channel then follow the procedure shown in figure- 33 by pressing the appropriate buttons given in the front panel of the chart recorder.

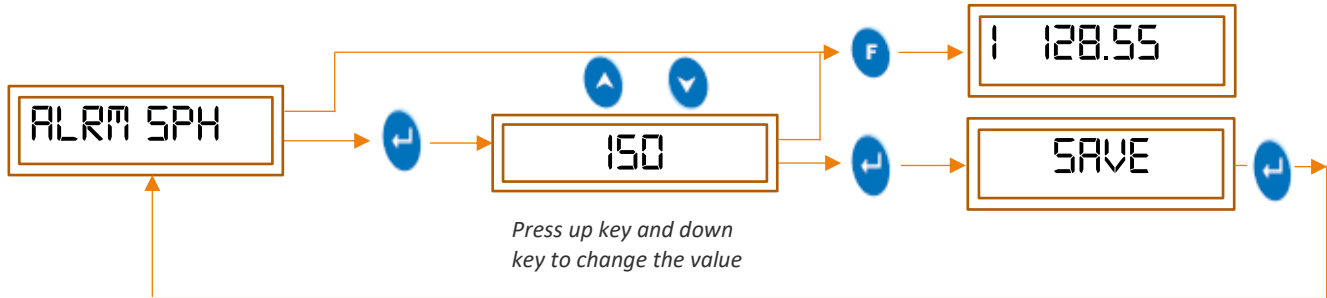

Figure 33 - Alarm Set point High

### 6.2.7.8 Set Point Low

In this parameter, we should set the value to alert us whenever device reading goes low than the set value, and that value should be set from -3276.8 to 3276.7

To set the Alarm Set point low for a single channel then follow the procedure shown in figure- 34 by pressing the appropriate buttons given in the front panel of the chart recorder.

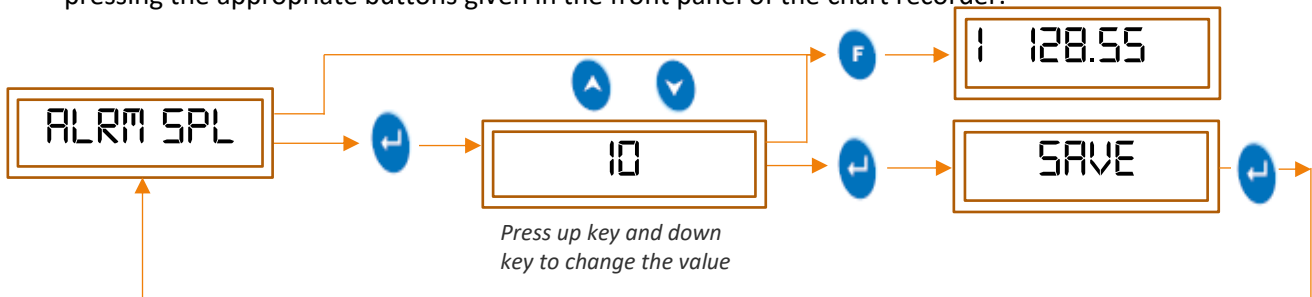

Figure 34 - Alarm Set Point Low

Above function Alarm set point high and Alarm set point low set the range, If the value increase and decrease from high and low range respectively then internal relay will activate the Industrial buzzer make sound till value will not come back within range.

### 6.2.7.9 Chart Zero

This feature is used for selecting the minimum value of the output which is considered as a zero scale on chart and other outputs are plotted with reference to zero scale value.

For example:

If the user wants to measure the temperature, then user needs to plot readings between 0 to 50 degrees Celsius. So, here user can set chart zero value as a 0-degree Celsius. So, Chart zero scale start from 0-degree Celsius. When output is 0-degree, chart plotted to zero and all readings plotted with reference to these zero scales.

Now, for the above case if the user wants to just plot the temperature if gone above 10-degree that is 10-50 degree then in this case the user should be set the value of chart zero as 10.



User can set the range low values anywhere between -3276.8 to 3276.7.

To set the Chart zero for single channel then follow the procedure shown in figure- 35 by pressing the appropriate buttons given in the front panel of the chart recorder.

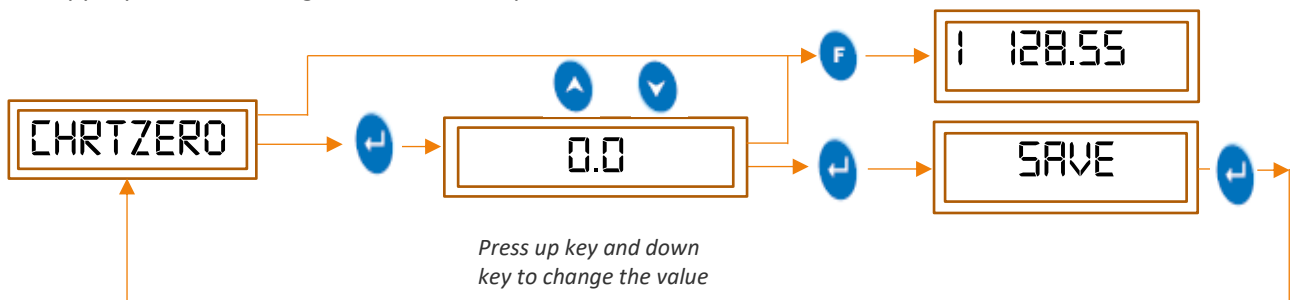

Figure 35 - Chart Zero

#### 6.2.7.10 Chart Span

Chart Span is the total range of chart counts when a user wants to plot.

Span value indicates the total interval of which all the count values will be plotted.

For example:

If the user wants to measure and plot temperature between the range of 0 to 100 degree Celsius, then user can set its Chart Span 100. So, Total CCR will plot the outputs between the range of 0 to 100.

Now, for the above case if the user wants to just measure and plot the temperature above 50-degree that is 50-100 degree then in this case the user should set the value of chart span as 50 and chart zero as 50. Chart Span = (100-50).

User can set the Span value anywhere between -3276.8 to 3276.7.

To set the chart span for a single channel then follow the procedure shown in figure- 36 by pressing the appropriate buttons given in the front panel of the chart recorder.

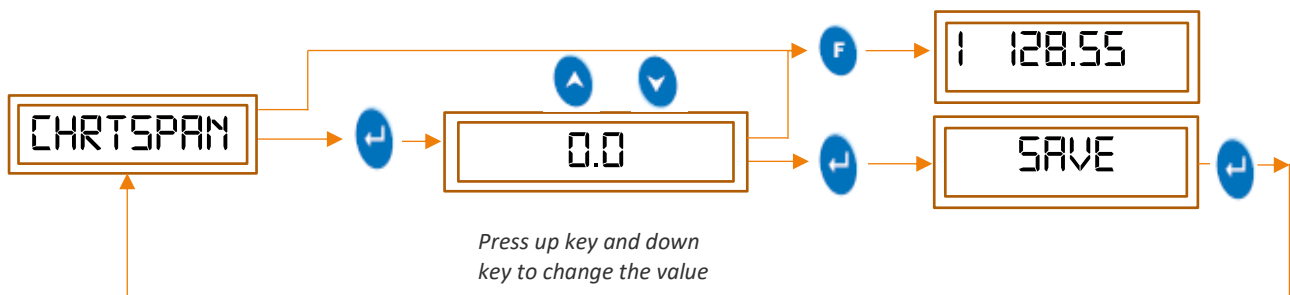

Figure 36 - Chart Span

#### 6.2.8 Channel 2

Same as Describe in Type of Functions [6.2.7 CHANNEL 1](#).

#### 6.2.9 Channel 3

Same as Describe in Type of Functions [6.2.7 CHANNEL 1](#).

#### 6.2.10 Channel 4

Same as Describe in Type of Functions [6.2.7 CHANNEL 1](#).

## 7 CALIBRATION

### 7.1 MECHANICAL CALIBRATION

Press UP, DOWN key at a time, chart recorder will enter in calibration mode.

This feature involves setting of “pen zero” and “pen full” scale on chart, through the front panel keyboard. This is how the user can set his minimum and maximum values of chart points according to his use by using the mechanical calibration. User can calibrate pen 1 or pen 2 of the Recorder by following the sequence.

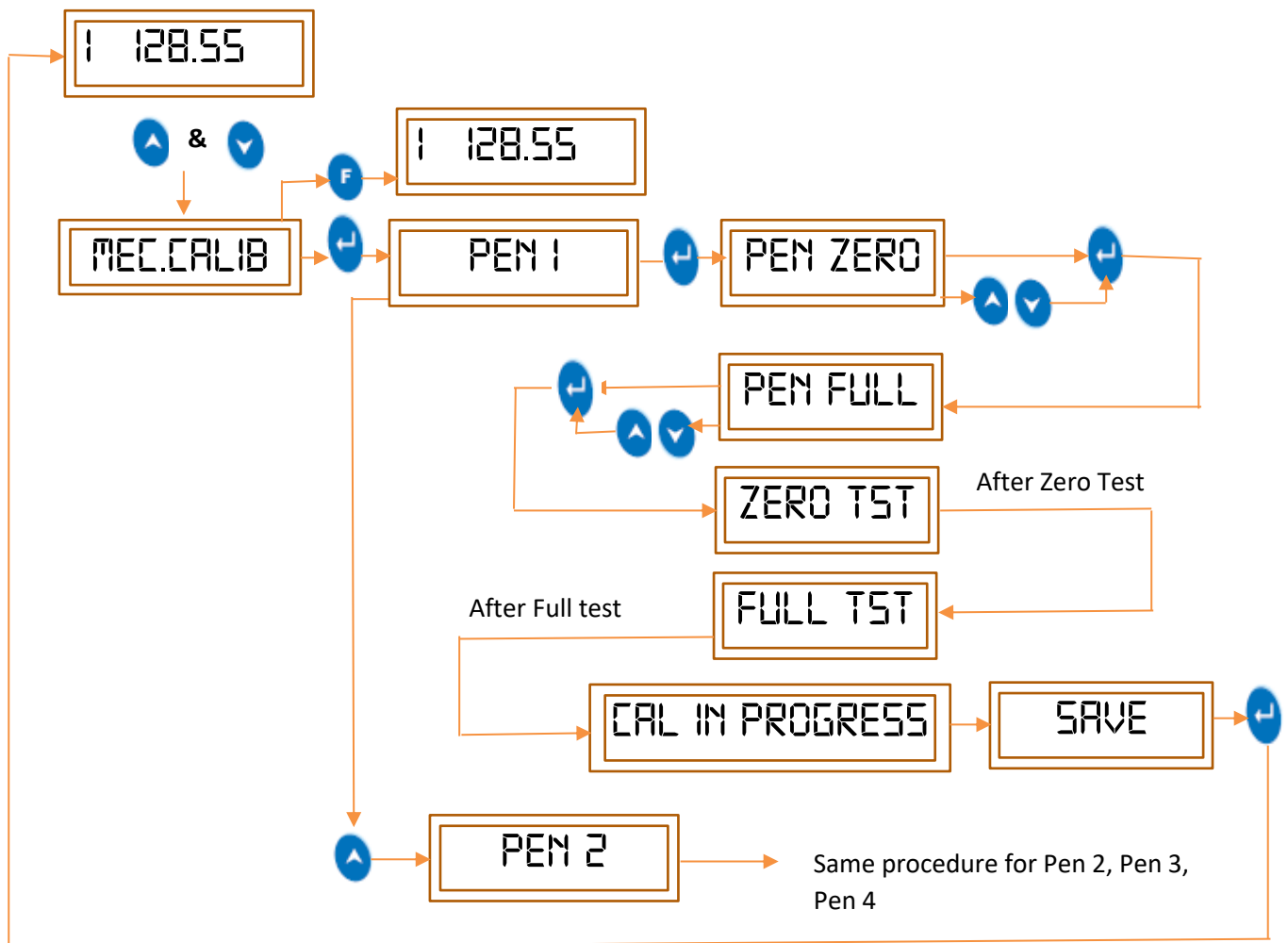



Figure 37 - Mechanical calibration

Note-   Up-Down keys are used to set the pen up or down.

All the pens of their individual different channels can be given different mechanical calibration according to the desired output. At “Zero Tst” pen moves on zero scale and hold for 5 seconds. At “Full Tst” pen moves on full scale and hold for 5 seconds.

Once user enter in Mechanical calibration, he can't go back to main menu without completion of calibration process or user can restart a device to come out of the mechanical calibration menu.

## 8 TROUBLESHOOTING GUIDE

Table 4 Troubleshooting Guide

PROBLEM	CORRECTIVE ACTION
Power Is ON but No Display	<ul style="list-style-type: none"> <li>• Check device switch whether it is ON or OFF</li> <li>• Check Power Supply at Customer Site.</li> </ul>
Display shows NAN continuously after connecting sensor	<ul style="list-style-type: none"> <li>• Check whether sensor is connected or not.</li> <li>• Sensor connection should be according to TABLE 2.</li> <li>• Change the sensor type according to sensor used in the menu of the channel to which the sensor input is provided</li> </ul>
Pen is not marking	<ul style="list-style-type: none"> <li>• Pen is dry, replace the Pen</li> <li>Check pen arm pressure.</li> </ul>
Chart does not move	<ul style="list-style-type: none"> <li>• Chart knob is loose</li> <li>• Check "CHART SPD"</li> <li>• Chart motor is having problem, contact G-Tek.</li> </ul>
Ink is blotting on the paper	<ul style="list-style-type: none"> <li>• Chart has absorbed moisture. Put in desiccator and remove moisture.</li> <li>• Excessive ink in Pen. Put the pen on blotting paper for some time and remove excess ink.</li> </ul>
Device not Working on battery	<ul style="list-style-type: none"> <li>• Battery voltage is not enough.</li> <li>• Check fuse is ok or not.</li> <li>• Use only 0.5A fast blow 20mm fuse.</li> <li>• Check battery polarity.</li> </ul>

Note: if you face any other problem please contact G-Tek Corporation Pvt. Ltd.

## 9 ACCESSORIES

### 9.1 STANDARD ACCESSORIES

Charts Pack of 30

Pens Pack of 5: 3 number (4 number for four channel)

Panel Mounting Clamps: 2 numbers

### 9.2 OPTIONAL ACCESSORIES

Wall Mounting Kit

Case to Panel Gasket

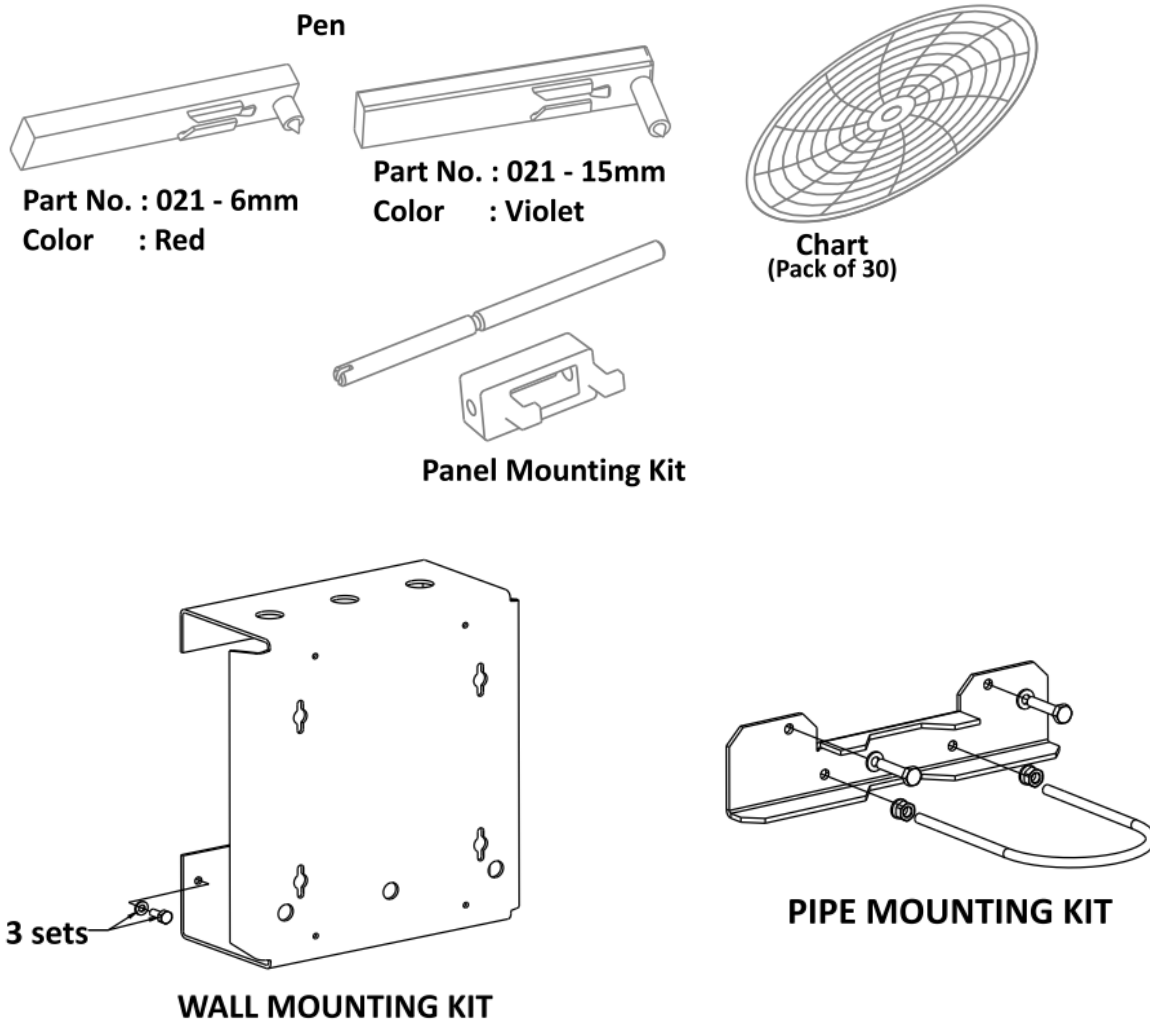

Figure 38 - Accessories

## 10 SPECIFICATION

The Specifications of chart recorder are:

Table 5 Specification of Chart Recorder

<b>Model No</b>	<b>CR2010 Pro; 11" recorder</b>
<b>Product Code*</b>	<b>3xxxx</b>
<b>Pens</b>	
<b>No. of Pens</b>	3/4
<b>Pen Marking</b>	Continuous
<b>Pen Response Time</b>	<5Sec (Full Scale)
<b>Pen Resolution</b>	Stepper Motor Controlled better than 0.1% FSD
<b>Overshoot</b>	None
<b>Chart</b>	
<b>Chart Speed</b>	15min/rev to 255 hours/rev
<b>Chart Calibrated Radius</b>	4.1" (approx. 107mm)
<b>Chart Ranges</b>	Standard (Refer Table 2) / Customized Please specify
<b>Display, Operator Panels and Input</b>	
<b>Display Type</b>	Digital, 8 digits ultra-bright LED Numeric/semi alphabetic
<b>Display Height</b>	0.3"
<b>Status Indicator</b>	Channel Number and corresponding parameter values, prompts and messages displayed for ease for setup and programming.
<b>Panel Keys</b>	Front panel KB consisting of 5 keys for programming and calibration
<b>Analog Input</b>	RTD PT-100 / 0-5V/ 4-20 mA / 0-20 mA (External shunt resistance)/TCJ-K-C-R-S-T-B-E-N
<b>Sensor Type and Range</b>	Refer to Table 1
<b>Scan Rate</b>	Continuous 1 reading per second
<b>Protection</b>	
<b>Input Impedance</b>	RTD/VOLT/TC >20mΩ

	<i>mA 50Ω Shunt External</i>
<b>CMRR</b>	>100 dB@ 50, 60 Hz at 3 Sample per Second
<b>NMRR</b>	>50 dB@ 50, 60 Hz at 3 Samples per Second
<b>Maximum Common Mode Voltage</b>	5V AC
<b>Isolation Channel – EARTH</b>	1.5KV 1 minute
<b>Input Protection</b>	30V AC/DC Max
<b>Termination</b>	Non-Interchangeable, Removable Plugs, Individual for Each Input
<b>Transmitter Power Supply</b>	Non-Isolated 24VDC; 30Ma max, un protected
<b>Environmental</b>	
<b>Temperature</b>	<i>(Operation)</i> 5°C to 45°C / <i>(Limiting)</i> 0°C to 50°C
	<i>(Storage)</i> -20°C to 60°C
<b>Humidity</b>	<i>(Operation)</i> 10 to 80 % RH Non-Condensing
	<i>(Storage)</i> 5 to 90 % RH Non-Condensing
<b>Altitude</b>	<2000 meter
<b>Power Requirement</b>	
<b>Supply Voltage (Mains Operated)</b>	85-264VAC 47-63Hz
<b>Battery backup</b>	Yes
<b>DC Adapter Operated</b>	Yes
<b>Power</b>	15W Max with Maximum Configuration
<b>Fuse Type</b>	None
<b>Battery Backup*:</b>	
<b>Battery</b>	12V 7Ah External Lead Acid battery
<b>Battery Charger</b>	Yes
<b>Battery Reverse Polarity</b>	Protected
<b>Minimum Back up</b>	>12 Hrs.
<b>Communication RS232/485*</b>	
<b>Protocol</b>	Proprietary
<b>Baud Rate</b>	4800
<b>Parity</b>	None

<b>Relay Output*:</b>	
<b>Max</b>	1 Relay per Analog Channel
<b>Output Type</b>	Potential Free Contact, 1 From C
<b>Configuration</b>	High/Low/High-Low/On-Off (Hysteresis band settable)
<b>Life expectancy</b>	Mechanical:10 <sup>7</sup> Operations Electrical :10 <sup>5</sup> Operations
<b>Load</b>	1A ,230V AC resistive
<b>Relay Refresh Rate</b>	1 Sec.
<b>Isolation Relay-Relay</b>	2.5KV 1Minute
<b>Isolation Relay Contact - GND</b>	1.5KV 1Minute
<b>Safety</b>	
<b>EMI-EMC</b>	IEC 61326-1 Class A
<b>Safety</b>	IEC 61010-1
<b>Pollution Degree</b>	II
<b>Installation Category</b>	III
<b>Vibration</b>	2g Peak (10Hz – 150Hz)
<b>Shock</b>	IEC61010-1
<b>IP Rating</b>	IP50(Door and Bezel Only)
<b>Overall Dimension</b>	
<b>Dimension L x W x D (mm)</b>	411X376X130
<b>Panel Cutout (mm) (L x W)</b>	319X323
<b>Bezel (mm)</b>	411X376

<b>Sensor Type</b>	<b>Standard</b>	<b>Range</b>	<b>Resolution</b>	<b>Accuracy</b>	<b>Display Range</b>
<b>RTD Type</b>			0.1	±0.5%FSD±1 Digit	-2000.0 to 2000.0
<b>Pt 100</b>	IEC751	-200 To +850			
<b>T/C Type</b>					
<b>J</b>	IEC584.1	-200TO +1200			
<b>K</b>	IEC584.1	-200 To +1300			
<b>C</b>	Hoskins	0 To +2300			
<b>R</b>	IEC584.1	0 To +1750			
<b>S</b>	IEC584.1	100 To +1750			
<b>T</b>	IEC584.1	-100 To +400			
<b>B</b>	IEC584.1	200 To +1800			
<b>E</b>	IEC584.1	-100 To +1000			
<b>N</b>	IEC584.1	-250 To +1300			
<b>mV</b>					
<b>Bipolar 1V</b>		±99999	0.1	±0.5%FSD±1 Digit	-2000.0 to 2000.0
<b>Unipolar 1V</b>		±99999	0.1	±0.5%FSD±1 Digit	-2000.0 to 2000.0
<b>Bipolar 5V</b>		±99999	0.1	±0.5%FSD±1 Digit	-2000.0 to 2000.0
<b>Unipolar 5V</b>		±99999	0.1	±0.5%FSD±1 Digit	-2000.0 to 2000.0
<b>mA</b>					
<b>4-20mA</b>		±99999	0.1	±0.5%FSD±1 Digit	-2000.0 to 2000.0
<b>0-20mA</b>		±99999	0.1	±0.5%FSD±1 Digit	-2000.0 to 2000.0

\*Actual specification may vary depending on the optional features installed.

\*\*Refer to the back panel of recorder for exact rating.



# 11 ORDERING CODE

Chart recorder order code is as below: -

Table 6 Order code of Chart Recorder

Chart Width Recorder type		Pen, Display		Power Supply		Relay		PC Interface	
CR		PD		PS		RE		PI	
3	CR11-NU	1	1P D	0	85-265 V CE	0	None	0	None
		2	2P D	1	12-15V DC	1	1	1	RS-232
		3	3P D	4	85-265V CE BB	2	2	4	TCP/IP
		4	4P D	5	85-265V CE With TS	3	3		
				7	85-265V CE BB With TS	4	4		
				8	24 V				

Chart Type (Table7)		Range		Chart Speed		S-Sensor Type	
CT		R		CS		S	
x	x	0	PG	0	P.G	0	Uni

Table 7 Chart type of Chart Recorder

Sr. No.	Range**	Speed	Size	Part No.	Part Description
51	0 to +100	24H	11"	301001	D110100
52	0 to +150	24H	11"	301008	D110150
53	0 to +200	24H	11"	301013	D110200
54	0 to +300	24H	11"	301017	D110300
55	0 to 1200	24H	11"	301007	D1101200
56	-50 to +50	24H	11"	301033	D11-5050
57	0 to +150 & -1 to +5	24H	11"	301011	D110150/-1+5 Dual Range
58	0 to +250 & 0 to +100	24H	11"	301015	D110250/ 0100 Dual Range
59	0 to +100 & 0 to +400	24H	11"	301004	D110100/0400 Dual Range
60	0 to +100 & -40 to +60	24H	11"	301005	D110100/-4060 Dual Range
61	0 to +80 & 0 to +160	24H	11"	301022	D11080/0160 Dual Range
62	0 to +100	7 Day	11"	302001	W110100
63	-100 to +50	7 Day	11"	302011	W11-10050
64	-50 to +50	7 Day	11"	302012	W11-5050
68	+40 to -10	7 Day	11"	302013	W11-4010
80	Other Please Specify				

\*\* The center of the chart is designated as range low value of recording.